

Vickers®

Directional Controls



Pilot Operated Directional Valves

DG3V-10 Hydraulic Pilot Operated; 1100 l/min (290 USgpm) 350 bar (5000 psi)
DG5V-10 Solenoid Pilot Operated; 1100 l/min (290 USgpm) 350 bar (5000 psi)
NFPA D10, ISO-4401-10, CETOP 10

Contents

DG3V-10 Remote Pilot Operated Directional Valves

Introduction	4
Model Code	5
Model Description/Performance Characteristics	6
Spool Type and Center Position	7
Pressure Drop	8
Installation Dimensions	9
Optional Features	10

DG5V-10 Pilot Operated Directional Valves

Model Code	11
Ratings/Model Description	13
Power Limits/Performance Characteristics	14
Shift Response Times	15
Spool Type and Center Position	16
Pressure Drop	17
Pilot Valves	18
Installation Dimensions	19
Optional Features	25
Electrical Information	27
Mounting Surface	37
Application Data	38

Introduction

General Description

The Vickers size 10 Directional Control Valve serves as a control valve package. This package is generally used to control large flows, to 1100 l/min (290 USgpm).

The size 10 Directional Valve has been developed to be the “Best in Class” product through Computation Fluid Dynamics and Finite Element Analysis. The low pressure drop makes it the top performer in its class.

This Directional Control Valve features the following pilot valves:

- DG3V-10 - remote pilot operated valve.
- DG5V-10-S uses the DG4V-3S-60 standard performance pilot.
- DG5V-10-H uses the DG4V-3-60 high performance pilot.
- DG5V-10-A uses the DG5S4-01-50 air gap pilot.
- DG5V-10-F uses the DG4V4-01-10 wet armature pilot.
- DG5V-10-V uses the DG4V5-20 wet armature pilot.
- DG5V-10-W uses the DG5S4-01-60 wet armature pilot.

Each valve contains a mainstage spool which is positioned by one of four special arrangements, which are:

- Spring offset - For single stage operation, one spring returns the spool to an offset position. For two-stage operation, the spring and washer are removed from the main stage and offset action is obtained from the pilot valve.
- Spring centered - The spring and washer are located on both ends of the main stage spool to control centering.
- Pressure centered - Centering springs are used in addition to pilot pressure to provide positive centering should pilot pressure fail.
- Detented - Spool position is determined by a detent in the pilot valve. Should pilot pressure be lost, the main stage spool will spring to center.

Features and Benefits

- The size 10 Directional Valve is designed and manufactured by Vickers, which has over 70 years of experience as the Global Leader in Fluid Power and Motion Control.
- The valve has been computer flow modeled in the core passages of the solid cast body to provide maximum flow at the lowest possible pressure drop. This enables Vickers to offer the best performance package in the industry.
- Endurance tested to 10 million cycles and fatigue tested to NFPA specifications without failure to ensure the highest reliability in applications requiring high flows and pressure.

- This control valve package offers a wide variety spool and spring arrangements, pilot choke adjustments, integral check valves and port orifices to meet most system requirements. High force solenoids and centering springs assure consistent shifting through a wide range of pressure and silting extremes.
- Electrical options including coil types, connections, and wiring housings allow full compatibility and reliable performance in any system application.
- Plain, waterproof, and lockable manual override options are available to facilitate system troubleshooting or servicing.
- The DG3V and DG5V models are functionally interchangeable with previous size 10 design valves. Should size constraints prevent physical interchangeability (along length axis), an EN503 option is available.

Service Information

Refer to specific Vickers parts drawing for service parts information.

Order by literature number.

DG3V-10	5007.05/EN/0196/S
DG5V-10-*A	5007.06/EN/0196/S
DG5V-10-*W	5007.06/EN/0196/S
DG5V-10-*S	5007.06/EN/0196/S
DG5V-10-*H	5007.06/EN/0196/S
DG5V-10-*F	5007.06/EN/0196/S
DG5V-10-*V	5007.06/EN/0196/S

Functional Symbols

Double Solenoid - Spring centered

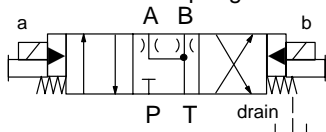

Double Solenoid - Detented

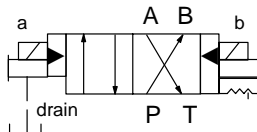

Double Solenoid - Pressure centered

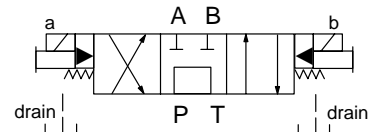

Single Solenoid - Shift to center

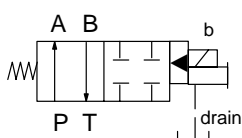

Single Solenoid - Spring offset

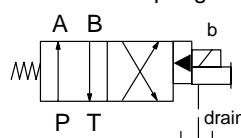

Single Solenoid - Spring centered

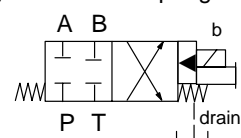

DG3V-10 Remote Pilot Operated Directional Valves

Model Code

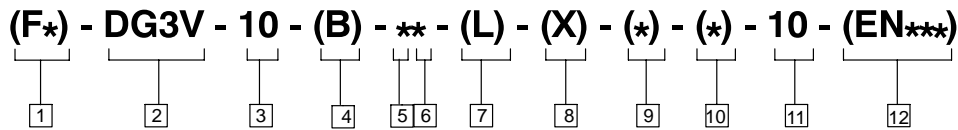

1 Special Seals

(Omit if not required)

F3 - Seals for fire resistant fluids.

F6 - Seals for water glycol.

2 Directional Control Valve

DG3V - Subplate mounting; pilot operated, remote operator. Pressure rating 350 bar (5000 psi) for P, A & B ports. (See pressure tabulation below.)

3 Valve Size

10 - Valve size CETOP 10, ISO 4401-10, NFPA D10

4 Gauge Ports

Blank - .4375-20 UNF-2B Thread
B - 1/4 BSP Thread

5 Spool Types

- 0 - Open to T all ports
- 1 - Open P&A to T, closed B
- 2 - Closed to T all ports
- 3 - Closed P&B, open A to T
- 4 - Tandem P to T, closed crossover
- 6 - Closed P only, open A&B to T
- 7 - Open P to A&B, closed T
- 8 - Tandem P to T, open crossover
- 9 - Open to T all ports over tapers
- 11 - Open P&B to T, closed A
- 31 - Closed P&A, open B to T

33 - Closed P, open A&B to T over tapers

52 - Closed center, regen. by sol. 'A'

521 - Closed center, regen. by sol. 'B'

6 Spool/Spring Arrangement

Blank - No spring

A - Spring offset to cylinder 'A'

C - Spring centered

D - Pressure centered 140-210 bar (2000 - 3000 psi)

(See spool/spring combinations below)

7 Left Hand Build

L - 'A' Models only, omit if not required.

8 Fast Response

X - Not available with CETOP 3 pilots or pressure centered 'D' and 'DB' models.

9 Spool Control Modifications

(Omit if not required)

1 - Stroke adjustment (both ends) available on C & Blank (no spring) models)

2 - Pilot choke adjustment (available on all models)

3 - Pilot choke and stroke adjusters (both ends) (available on C & Blank (no spring) models)

7 - Stroke adjusters on cylinder 'A' end only (available on AL, C & Blank (no spring) models)

8 - Stroke adjusters on cylinder 'B' end only (available on AL, C, & Blank (no spring) models)

2-7 - If both are required (available on A, C, & Blank (no spring) models)

2-8 - If both are required (available on AL left hand build, C & Blank (no spring) models)

10 Check Valve in Pressure Port

Not available for 'D' models
 Omit if not required.

K - 0,3 bar (5 psi) check

Q - 2,4 bar (35 psi) check

R - 3,4 bar (50 psi) check

S - 5,2 bar (75 psi) check

11 Design Number

Subject to change. Installation dimensions remain as shown for design numbers 10 through 19.

12 Special Modifications

(Omit if not required)

EN503- Reduced overall axial length for close quarter applications.

Ratings - NFPA fatigue rated to 350 bar (5000 psi)*

Maximum Operating Pressure (Ports P, A, & B) (bar psi)	Maximum Pilot Pressure bar (psi)	Maximum Tank Line Pressure bar (psi)	Mounting Pattern
350 (5000)	210 (3000)	210 (3000)	CETOP 10 ISO 4401-10 NFPA D10

* See power limits chart on page 7.

Spool/Spring Arrangement

The table at right provides spool/spring arrangements that are available on all DG3V-10 valves.

Spool/Spring Arrangement	Spool Type
A-Spring Offset	0,2,6,9,33
Blank C-Spring Centered	0,1,2,3,4,6,7,8,9,11,31,33,52,521
D-Pressure Centered	0,1,2,3,4,6,8,9,33

Model Description/Performance Characteristics

Model Description Spring Offset (A)

Spring offset models have an internal spring which offsets the spool when pilot connection 'X' is open to tank. When pressure is removed, the spring is used to return the spool to an offset position.



CAUTION: Spring offset models contain a high assembled spring load. Call Vickers Service for disassembly instruction.

Spring Centered (C)

A spring and washer arrangement is used on both ends of the spool. If pilot pressure is removed, the valve will go to center position due to spring force.

Pressure Centered (D)

This model provides faster spring centering time by using pilot pressure to center the spool. The centering springs are used in addition to pilot pressure to ensure positive centering of the spool.

Note

Pressure centered valves require pilot pressure to direct oil to connections "X" or "Y" when pressure centering is desired.

The spring centering time depends on the rate at which the pilot oil reaches the pilot chambers (see examples on page 10).

No-Spring

Spool is shifted by pilot pressure. When pilot pressure is removed, the spool remains in last shifted position but is free to float.

Mounting Position

The mounting position of spring centered and spring offset models is unrestricted provided that the pilot pressure supply is maintained.

Performance Characteristics Shifting Action

Spring centered, pressure centered, spring offset, and no-spring models must be piloted continuously to maintain the shifted position.

Spring offset models return spool to offset position by pilot pressure when pilot pressure is removed.

Pressure centered and spring centered models return valve spool to center position when pilot pressure is removed.



CAUTION: Flow conditions of the spring centered position must be selected with care, both for the effect on the direction of the flow, and the pilot pressure. (The "9" main spool will not ensure sufficient pilot pressure in the center position.)

When pilot pressure is removed, valve spool is returned to center position by pilot pressure in pressure centered models. If pilot pressure fails or falls below the required minimum, the valve spool will spring return to center position. (At spring centered valve flow rates).



CAUTION: Surges of oil in a common tank line serving these and other valves can be sufficient enough to cause inadvertent shifting of these valves. This is very critical in the no-spring detented valves. Separate tank lines or a vented manifold with a continuous downward path to tank is necessary.

Note

Any sliding spool valve, if held for long periods of time, may stick and not spring return due to fluid residue formation and therefore, should be cycled periodically to prevent this from happening.

When used as other than a normal 4-way valve, consult your Vickers representative.

Shift Times

Shift times are defined as the time from pilot pressure application/removal to the point of the start of a pressure rise/decline in appropriate port.

Minimum Pilot Pressure Requirements

Note

Pilot pressure must not exceed 210 bar (3000 psi) for models with maximum stroke adjustments.

Spool Type	Flow l/min (USgpm)	Shifting P to A bar (psi)		Shifting P to B bar (psi)	
		Pressure Centered Models●	All Other Models	Pressure Centered Models●	All Other Models
All Spools	0	5 (75)	5 (75)	14 (200)	5 (75)
0, 4, 8 & 9	946 (250)	5 (75)	5 (75)	14 (200)	5 (75)
2, 3, 6 & 33	946 (250)	10 (150)	10 (150)	27,5 (400)	10 (150)

- On pressure centered models, end covers cannot be interchanged. Pilot pressure is not available through use of integral check valves.

Spool Type and Center Position

Spool Type and Center Position

Spool Type	Center Position	Spool Type	Center Position	Spool Type	Center Position	Spool Type	Center Position	Spool Type	Center Position
0		3		7		11		52	(Below)
1		4	(Closed Crossover) 	8	(Open Crossover) 	31			
2		6		9		33			

Graphical Symbols

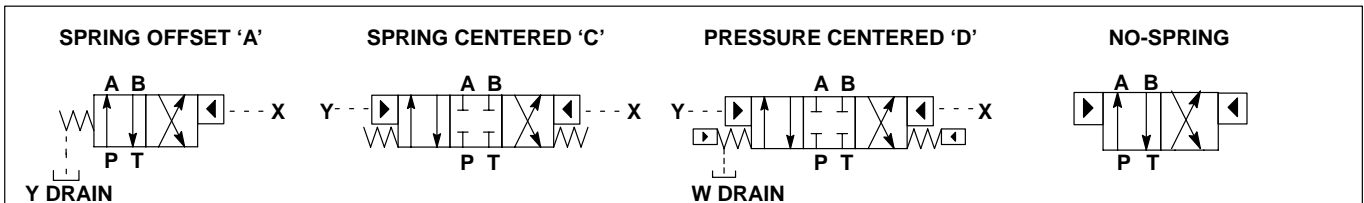

Power Limits @ 10 bar (150 psi) Pilot Pressure

3 Position Valve & Spring Centered

Spool Types	Pressure - bar (psi)				
	70 (1000)	140 (2000)	210 (3000)	280 (4000)	350 (5000)
	L/min (USgpm)				
2, 3, 6, 7, 33 & 52	1100 (290)	1078 (285)	1022 (270)	832 (220)	757 (200)
9	1100 (290)	1040 (275)	719 (190)	662 (175)	473 (125)
0, 4 & 8	946 (250)	889 (235)	851 (225)	757 (200)	662 (175)
1 & 11	946 (250)	681 (180)	454 (120)	321 (85)	321 (85)

2 Position (Spring Offset Mainstage)

0, 2, 6, 9 & 33	1100 (290)	1078 (285)	1022 (270)	832 (220)	757 (200)
-----------------	------------	------------	------------	-----------	-----------

Pressure Centered

0, 1, 2, 3, 4, 6, 8, 9 & 33	946 (250)	946 (250)	946 (250)	N/A	N/A
-----------------------------	-----------	-----------	-----------	-----	-----

Pressure Drop

Pressure Drop

The following table lists the appropriate pressure drop curve between ports for each spool type. Use the following example to determine pressure drop for a selected spool.

Example: Find the pressure drop from P→B for type 7 spool. Using the table find numeral 7 in the spool type column. To the right of numeral 7 find the reference curve 5 (from pressure drop curve chart at bottom of page) under P→B column.

The pressure drop from P→B for type 7 spool would be obtained on curve 5.

Spool Type	Pressure Drop Curve Number				
	P→A	B→T	P→B	A→T	P→T On Center
0	5	5	5	6	4
1	2	2	5	6	7
2	1	2	1	1	–
3	2	2	5	1	–
4	7	9	7	9	8
6	1	5	1	5	–
7	5	3	5	3	–
8	3	3	3	3	6
9	1	2	1	1	–
33	1	2	1	1	–
52	3	▪	3	3	–

▪ Contact your Vickers representative.

Pressure Drop Curves

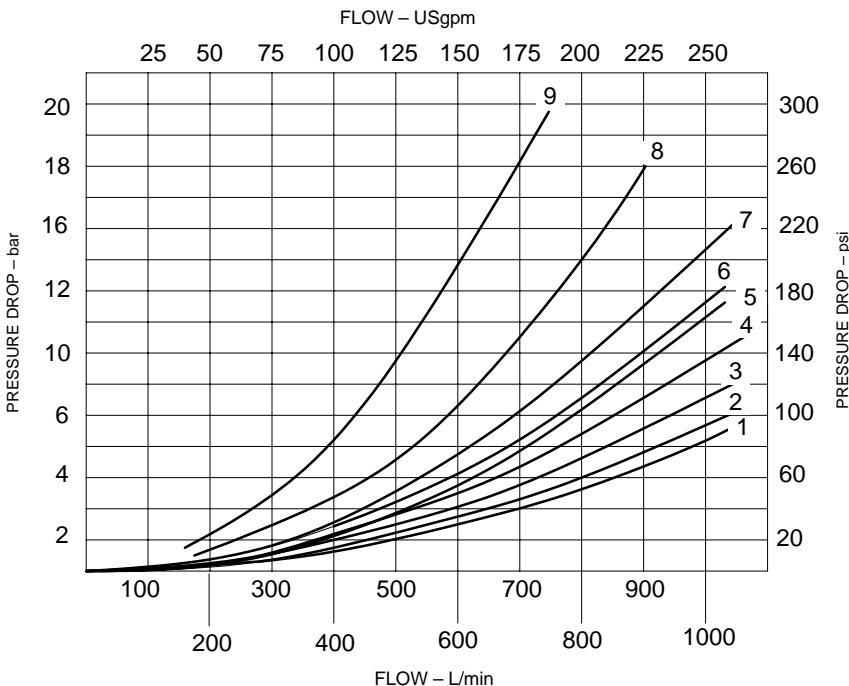

1. Figures in the pressure drop chart give approximate pressure drop (ΔP) when passing 473 l/min (125 USgpm) flow (Q) of 35 cSt (164 SUS) fluids(s) having .865 specific gravity.
2. For any other flow rate (Q_1), the pressure drop (ΔP_1) will be approximately: $\Delta P_1 = \Delta P(Q_1/Q)^2$.
3. For any other viscosity(s), the pressure drop (ΔP), will change as follows:

Viscosity	14	20	43	54	65	76	85
cSt	14	20	43	54	65	76	85
(SUS)	(17.5)	(97.8)	(200)	(251)	(302)	(352)	(399)
% of ΔP (Approx.)	81	88	104	111	116	120	124

4. For any other specific gravity (G_1)*, the pressure drop (ΔP_1) will be approximately: $\Delta P_1 = \Delta P(G_1/G)$.

Installation Dimensions

Millimeters (inches)

DG3V-10 Spring Centered & Spring Offset Models

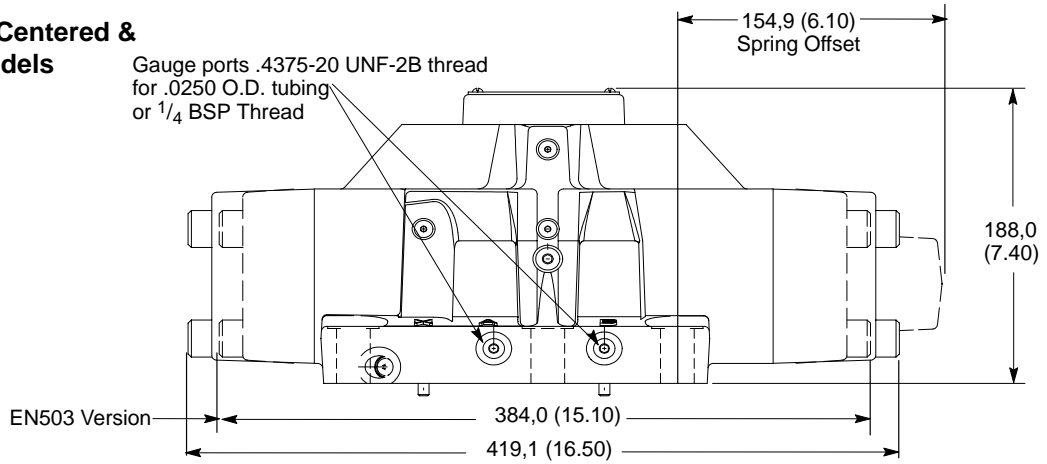

DG3V-10 Pressure Centered Models

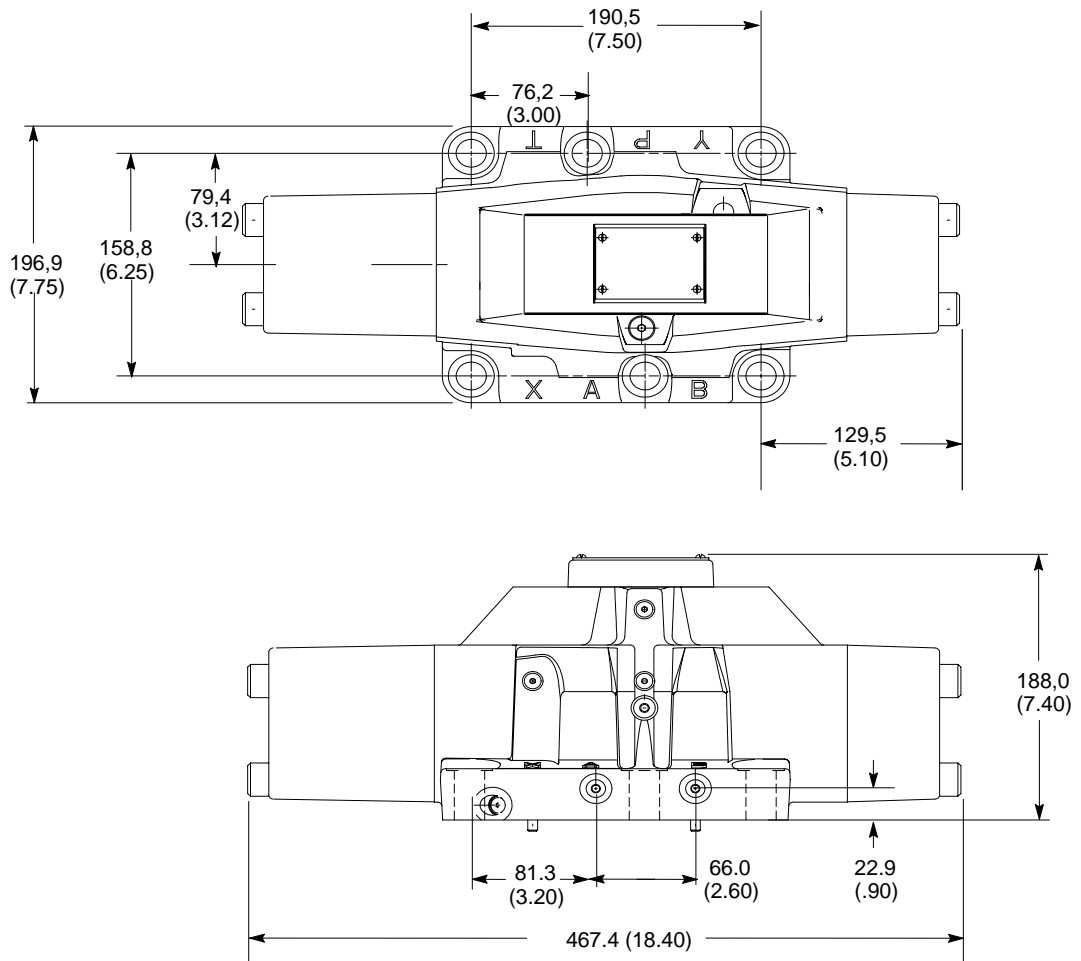

Optional Features

Integral Check Valves

For internal pilot pressure, an integral pressure port check valve is required for internally piloted valves with open center spools (0,1,4,8 & 9). The pilot pressure generated is the total of: P→T drop through the valve in center condition, pressure drop through the check valve, plus the pressure at the tank port.

For proper operation, pressure drop must be greater than the minimum required pilot pressure (see chart). To prevent load drop, a check valve in the pressure port can be used to prevent reverse flow from "A" cylinder port to pressure port. If using as reverse flow check, maximum reverse pressure is limited to 210 bar (3000 psi).

Pressure Drop Across Check Valve

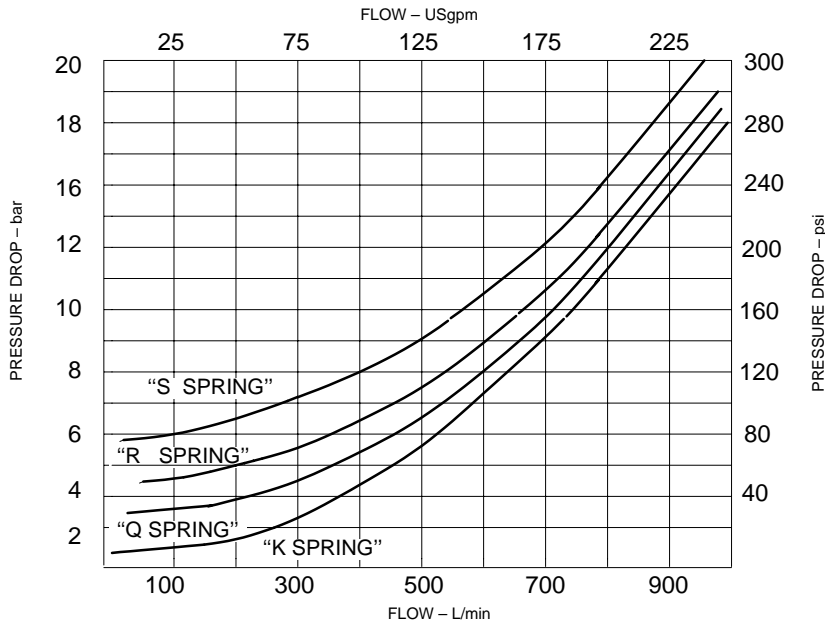

Pilot Choke

DGMFN-5-Y-A1W-B1W-30

Pilot choke increases the amount of time to shift the mainstage spool, lowering the possibility of large flow transients in the circuit. It is adjusted by backing off locknuts and turning adjusting screws inward to decrease rate of spool travel and outward to increase spool travel rate. See spool control modifications in model code.

Stroke Adjustments

Stroke adjustment limits movement of the mainstage spool. Backing off the locknut and turning the adjusting screw inward decreases spool stroke. See spool control modifications in model code.

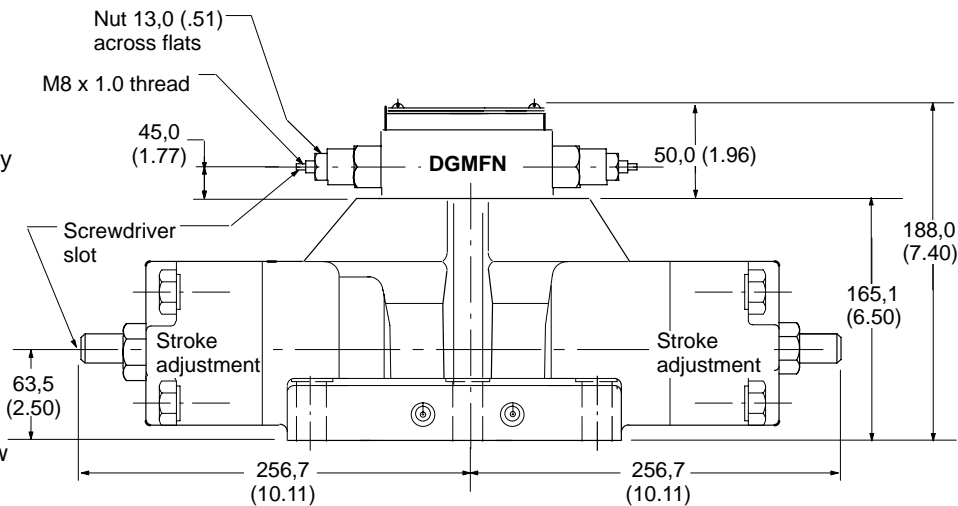

DG5V-10 Pilot Operated Directional Valves

Model Code

(F*) - DG5V -10- * - (R) - (B) - ** - (L) - (***) - (X) - (*) - (E) - (T) - (*) - (V)M - (S*) - * * * * - (L) - (*) - ** - (***) - 10 - (EN***)

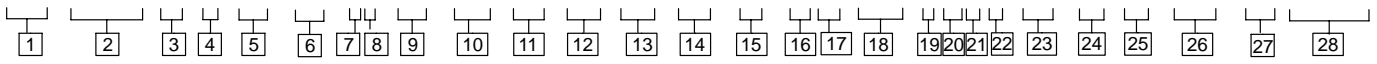

1 Special Seals
(Omit if not required)
F3 - Seals for fire resistant fluids.
F6 - Seals for water glycol.

2 Directional Control Valve
DG5V - Subplate mounting; solenoid controlled; pilot operated. Pressure rating 350 bar (5000 psi) for P, A, & B ports. (See maximum pressure tabulation on pg. 13.)
Note
Note: 210 bar (3000 psi) for pressure centered D models.

3 Valve Size
10 - Valve size CETOP 10, ISO 4401-10, NFPA D10

4 Pilot Valve Type
H - CETOP 3 mounting pattern, High performance
S - CETOP 3 mounting pattern, Std. performance
A - CETOP 5 mounting pattern, Air gap
F - CETOP 5 mounting pattern, Wet armature
V - CETOP 5 mounting pattern, Wet armature
W - CETOP 5 mounting pattern, Wet armature
(See pg. 18 for descriptions)

5 Reducer Module
(Omit if not required)
R - A (air gap) and W (wet armature) piloted models when pilot pressure exceeds 210 bar (3000 psi); F and V (wet armature) when pilot pressure exceeds 310 bar (4500 psi).

6 Gauge Ports
Blank - .4375-20 UNF-2B Thread
B - 1/4 BSP Thread
M - ISO 6149 port

7 Spool Types
0 - Open to T all ports
1 - Open P&A to T, closed B
2 - Closed to T all ports

3 - Closed P&B, open A to T
4 - Tandem P to T, closed crossover
6 - Closed P only, open A&B to T
7 - Open P to A&B, closed T
8 - Tandem P to T, open crossover
9 - Open to T all ports over tapers
11 - Open P&B to T, closed A
31 - Closed P&A, open B to T
33 - Closed P, open A&B to T over tapers
52 - Closed center, regen. by sol. 'A'
56 - A&B to T, P blocked, regen. by sol. 'A'
521 - Closed center, regen. by sol. 'B'
561 - A&B to T, P blocked, regen. by sol. 'B'

8 Spool/Spring Arrangement
A - Spring offset
B - Spring centered with solenoid 'A' removed
C - Spring centered
D - Pressure centered 210-350 bar (2000-3000 psi)
DA - Pressure centered 20-70 bar (300-1000 psi)
DB - Pressure centered 70-210 bar (1000-2000 psi)
N - Detented
(See pg. 13 for spool/spring combinations)

9 Left Hand Build
L - Single solenoid models only, omit if not required.

10 Manual Override Options
CETOP 3 piloted models only, omit if not required.
Blank - Plain override in solenoid ends only.
H - Waterproof override in solenoid ends only.
H2 - Waterproof override in both ends of single solenoid.
P2 - Plain override in both ends of single solenoid.
Y - Lockable manual override in solenoid ends only.
Z - No override in either end.

11 Fast Response
X - (Omit for standard internal pilot pressure models)
Note
Not available for pilot pressures above 210 bar (3000 psi), pressure centered models must have 'DA' 20-70 bar (300-1000 psi) in model code. Not available for H or S piloted models.

12 Spool Control Modifications
(Omit if not required)
1 - Stroke adjustment (both ends) (available on B, C, & N models)
2 - Pilot choke adjustment (available on all models)
3 - Pilot choke and stroke adjustments (both ends) (available on B, C, & N models)
7 - Stroke adjustment on cylinder 'A' end only (available on A, B, C, & N models)
8 - Stroke adjustment on cylinder 'B' end only (available on AL, B, C, N, & D(*) models)
2-7 - If both are required (available on A, B, C, & N models)
2-8 - If both are required (available on AL, B, C, N, & D(*) models)

CAUTION
 Stroke adjust pilot pressure models are rated to a maximum of 210 bar (3000 psi). Use reducer module if pilot pressure exceeds 210 bar (3000 psi).

13 External Pilot Pressure
E - External pilot pressure. Omit for internal pilot pressure models.

14 Internal Pilot Drain
T - Internal pilot drain to 'T' port. Omit for external pilot drain models.

15 Check Valve in Pressure Port
Not available for D(*) models. Omit if not required.
K - 0,3 bar (5 psi) check
Q - 2,5 bar (35 psi) check
R - 3,5 bar (50 psi) check
S - 5, bar (75 psi) check

Model Code (continued)

16 Solenoid Energization Identity

Blank - Standard arrangement for ANSI B93.9 (i.e. energize solenoid A to follow flow P to A).

V - Solenoid identification determined by position of solenoid (i.e. solenoid A at port A end/solenoid B at port B end).

Note

4 and 8 type spools are always V. Solenoid energization identity is independent of mainstage porting.

17 Heading Electrical Flag Symbol

M - Features and options for pilot valve.

18 Pilot Valve Monitoring Switch

(Omit if not required)

S - Indicator switch

(A & W piloted models only)

S3- Limit switch normally open, wired to electrical connector with PA/PB/PA5 (H piloted models only)

S4- Limit switch normally closed, wired to electrical connector with PA/PB/PA5

(H piloted models only)

S5- Limit switch - FW, FJ (H piloted models only)

S6- Position switch with U coils (H piloted models only)

19 Coil Type

F - Flying lead (required for wiring housing option)

KU - Top exit flying lead (H & S piloted models only)

P - Plug in (H & S piloted models only)

SP1- Single 6.3mm spade (H & S piloted models only)

SP2- Dual 6.3mm spade (H & S piloted models only)

U - ISO 4400 (DIN 43650)

X - Explosion proof solenoids ('A' piloted models only)

X1 - Flameproof solenoids BASEEFA/CENELEC (S piloted models only)

X2 - Explosion proof solenoids CSA/UL (S piloted models only)

X3 - Explosion proof solenoids BASEEFA ExS (S piloted models only)

20 Electrical Connections

(F type coils only, omit if not required)

PA - Insta-plug, male receptacle only

PB - Insta-plug, male and female receptacle

PA3- 3-pin connector

PA5- 5-pin connector

PM4-Mini-connector

T - Wired terminal block (wiring housing option also required)

21 Wiring Housing

Blank - Optional for A & W piloted models only

W - 1/2" NPT threaded connection

J - 20mm threaded connection

22 Electrical Options

(Omit if not required)

U-type coils only

1- Fitted connector

2- Fitted connector and variable grommet

3- Fitted connector with lights

23 Solenoid Indicator Lights

(Omit if not required)

24 Surge Suppressor/Damper

DC voltages only, omit if not required. For H, S, & W piloted models only.

D1- Encapsulated diode (industrial applications)

D2- Encapsulated diode (mobile applications)

D7- Encapsulated tranzorb

25 Coil Voltage Identification Letter

See electrical information on page 27 for voltages available. Others available upon request.

26 Pilot Valve Port Orifices

For H & S piloted models only, omit if not required.

27 Design Number

Subject to change. Installation dimensions same for -10 thru -19 design.

28 Special Modifications

(Omit if not required)

EN503- Reduced overall axial length for close quarter applications.

Ratings/Model Description

Ratings - NFPA fatigue rated to 350 bar (5000 psi)

Maximum Operating Pressure* (Ports P, A, & B) bar (psi)	Maximum Pilot Pressure ** bar (psi)	Maximum Tank Line Pressure bar (psi)		Mounting Pattern
		External Drain Models	Internal Drain Models	
350 (5000)	210 (3000)	210 (3000)	210 (3000) A	CETOP 10 ISO- 4401-10 NFPA D10
	210 (3000)	210 (3000)	70 (1000) W	
	350 (5000)	210 (3000)	100 (1450) S	
	350 (5000)	210 (3000)	210 (3000) H	
	310 (4500)	210 (3000)	120 (1750) Std. Power/70 (1000) Low Watt F	
	310 (4500)	210 (3000)	120 (1750) AC/160 (2300) DC V	

* See pilot pressure requirements on page 16.

** Any model with stroke adjustment - 210 bar (3000 psi)
Pressure Centered Models - 210 bar (3000 psi)

Model Description Pressure Centered

The pressure centered model provides more positive spool centering through greater force. Centering springs are used in addition to pilot pressure, to ensure centering, should pilot pressure fail. Pressure centered models require a minimum of 10 bar (150 psi) for pilot pressure. The pilot pressure is not available through the use of an integral check valve (see integral check valve description under optional features).

The chart below provides times for DG5V-10 Pressure Centered Models. The times are shown with various pilot pressures. Values shown for model 'DA' are with Fast response option (see Fast Response description under optional features). Fast Response is not available with 'D' or 'DB' models.

Spring Offset

The pilot valve spool is spring offset to one side. When the solenoid is de-energized, the spring returns the pilot spool to the offset position which directs pilot flow to offset the mainstage spool. When pilot pressure is removed, the spool remains in the last shifted position but is free to float.

Spring Centered

A spring and washer arrangement is used on both ends of the spool. If control pressure is removed, the valve will go to center position due to spring force.

Detented

When detented models are de-energized, the pilot and main spools remain in the last position attained, provided there is no shock, vibration, unusual pressure transients and the spool axis is horizontal. If pilot pressure fails or falls below the minimum, the main spool will spring center (at spring centered flow rates) and cannot drift to reversal of flow (pilot stage remains in a detented position).

Model	DG5V-10 Pressure Centering DG Valves (Typical centering times in seconds)		
	Pilot Pressure - bar (psi)	"B" to Center - seconds	"A" to Center - seconds
"DA"	10 (150)	.104 (104 mS)	.144 (144 mS)
	17 (250)	.080 (80 mS)	.108 (108 mS)
	70 (1000)	.056 (56 mS)	.064 (64 mS)
"DB"	70 (1000)	.064 (64 mS)	.085 (85 mS)
	140 (2000)	.060 (60 mS)	.080 (80 mS)
"D"	140 (1000)	.065 (65 mS)	.092 (92 mS)
	210 (3000)	.060 (60 mS)	.076 (76 mS)

Spool/Spring Arrangement

The table at right provides spool/spring arrangements that are available on all DG5V-10 valves.

Spool/Spring Arrangement	Spool Type
A-Spring Offset	0,2,6,9,33
B-Spring Centered with sol. "A" removed	0,1,2,3,4,6,7,8,9,11,31,33
C-Spring Centered N-No Spring Detented	0,1,2,3,4,6,7,8,9,11,31,33, 52,56,521,561▪
D-Pressure Centered	0,1,2,3,4,6,8,9,11,33

▪ 4 or 8 type spools not available on 'N' models with 'A' or 'W' pilots

Power Limits/Performance Characteristics

Power Limits @ 10 bar (150 psi) Pilot Pressure

3 Position Valve & Spring Centered

Spool Types	Pressure - bar (psi)				
	70 (1000)	140 (2000)	210 (3000)	280 (4000)	350 (5000)
	L/min (USgpm)				
2, 3, 6, 7, 33 & 52	1100 (290)	1078 (285)	1022 (270)	832 (220)	757 (200)
9	1100 (290)	1040 (275)	719 (190)	662 (175)	473 (125)
0, 4 & 8	946 (250)	889 (235)	851 (225)	757 (200)	662 (175)
1 & 11	946 (250)	681 (180)	454 (120)	321 (85)	321 (85)
2 Position (Spring Offset Mainstage)					
0, 2, 6, 9 & 33	1100 (290)	1078 (285)	1022 (270)	832 (220)	757 (200)
1, 11	946 (250)	681 (180)	454 (120)	321 (85)	321 (85)
Pressure Centered					
0, 1, 2, 3, 4, 6, 8, 9, 11, 31 & 33	946 (250)	946 (250)	946 (250)	N/A	N/A

Performance Characteristics

Shifting Action

Spring centered, pressure centered, and spring offset models must be piloted continuously to maintain the shifted position. Detent no-spring models may be energized momentarily (approximately 0.1 second).

Pressure centered and spring centered models return valve spool to center position when solenoids are de-energized.

Spring offset models return spool to offset position by pilot pressure when solenoids are de-energized.



CAUTION: Spring offset models contain no offset springs in the main stage and are hydraulically offset via spring offset pilots. When pilot pressure falls below the minimum shift pressure, the main stage spool is free to float.

When detented models are de-energized, the pilot and main spools remain in the last position attained, provided there is no shock, vibration, unusual pressure transients and the spool axis is horizontal.

If pilot pressure fails or falls below the minimum, the main spool will spring center (at spring centered flow rates) and cannot drift to reversal of flow (pilot stage remains in detented position).



CAUTION: Flow conditions of the spring centered position must be selected with care, both for the effect on the direction of the flow, and the pilot pressure. (The “9” main spool will not ensure sufficient pilot pressure in the center position.)

Pressure centered models: Valve spool is returned to center position by pilot pressure, when pilot pressure is removed. If pilot pressure fails or falls below the required minimum, the valve spool will spring return to center position. (At spring centered valve flow rates.)



CAUTION: Surges of oil in a common tank line serving these and other valves can be sufficient enough to cause inadvertent shifting of these valves. This is very critical in the no-spring detented type valves. Separate tank lines or a vented manifold with a continuous downward path to tank is necessary.

Note

Any sliding spool valve, if held for long periods of time, may stick and not spring return due to fluid residue formation and therefore, should be cycled periodically to prevent this from happening.

When used as other than a normal 4-way valve, consult your Vickers representative.

Shift Response Times

Response Times

Response times are defined as the time from solenoid energization/de-energization to the point of the start of a pressure rise/decline in appropriate port.

Solenoid Energizing

Spring centered, pressure centered and spring offset DG5V-10 types must be energized continuously. Detented DG5V-10 type may be energized momentarily. Pressure centered and spring centered DG5V-10 types return valve spool to center position when both solenoids are de-energized.

Mounting Position

No-spring detented valves must be installed with the longitudinal axis horizontal for good machine reliability. The mounting position of spring centered and spring offset models is unrestricted provided that the pilot pressure supply is maintained as required. (Spring offset valves do not have a spring in the main spool section.)

Shift Response Times with CETOP 3 Pilot (Fast Response option not available)

Valve Type	Condition	Pilot Pressure 10 bar (150 psi)		Pilot Pressure 100 bar (1500 psi)		Pilot Pressure 210 bar (3000 psi)	
		Voltage		Voltage		Voltage	
		"AC"	"DC"	"AC"	"DC"	"AC"	"DC"
3-Position Spring Centered	Pilot Pressure Applied Shift from Center to Offset	50 mS	80 mS	45 mS	60 mS	35 mS	55 mS
2-Position Spring Offset	Pilot Pressure Applied Shift from Offset to Offset	200 mS	210 mS	90 mS	130 mS	75 mS	100 mS
3-Position Spring Centered	Pilot Pressure Removed Shift from Offset to Center	50 mS	75 mS	50 mS	75 mS	50 mS	75 mS
2-Position Spring Offset	Pilot Pressure Removed Shift from Offset to Offset	50 mS	80 mS	50 mS	80 mS	50 mS	80 mS

Shift Response Times With CETOP 5 Pilot (Fast Response option not available for pilot pressures over 140 bar (2000 psi))

Valve Type	Condition	Pilot Pressure 10 bar (150 psi)		Pilot Pressure 100 bar (1500 psi)		Pilot Pressure 210 bar (3000 psi)	
		Voltage		Voltage		Voltage	
		"AC"	"DC"	"AC"	"DC"	"AC"	"DC"
3-Position Spring Centered	Pilot Pressure Applied Shift from Center to Offset (Standard/Fast Response)	50/50 mS	80/80 mS	45/25 mS	75/60 mS	37/NA mS	70/NA mS
2-Position Spring Offset	Pilot Pressure Applied Shift from Offset to Offset (Standard/Fast Response)	185/175 mS	240/190 mS	85/70 mS	130/125 mS	50/NA mS	115/NA mS
3-Position Spring Centered	Pilot Pressure Removed Shift from Offset to Center (Standard/Fast Response)	50 mS	80 mS▲	50 mS	80 mS▲	50 mS	80 mS▲
2-Position Spring Offset	Pilot Pressure Removed Shift from Offset to Offset (Standard/Fast Response)	75 mS	110 mS▲	50 mS	110 mS▲	30/NA mS	110/NA mS▲

▲ "DC" pilot runs without arc suppression devices. If diodes or other devices are used, de-energize times will be longer.

Spool Type and Center Position

Spool Type and Center Position

Spool Type	Center Position	Spool Type	Center Position	Spool Type	Center Position	Spool Type	Center Position	Spool Type	Center Position
0		3		7		11		52	
1		4 (Closed Crossover)		8 (Open Crossover)		31			
2		6		9		33			

Minimum Pilot Pressure Requirements (when operating at 210 bar (3000 psi) maximum)

Spool Type	Flow l/min (USgpm)	Shifting P to A bar (psi)		Shifting P to B bar (psi)	
		Pressure Centered Models●	All Other Models	Pressure Centered Models●	All Other Models
All Spools	0	5 (75)	5 (75)	14 (200)	5 (75)
0, 4, 8 & 9	946 (250)	5 (75)	5 (75)	14 (200)	5 (75)
2, 3, 6 & 33	946 (250)	10 (150)	10 (150)	27,5 (400)	10 (150)

● On pressure centered models end covers cannot be interchanged. Pilot pressure is not available through use of integral check valves.

Graphical Symbols

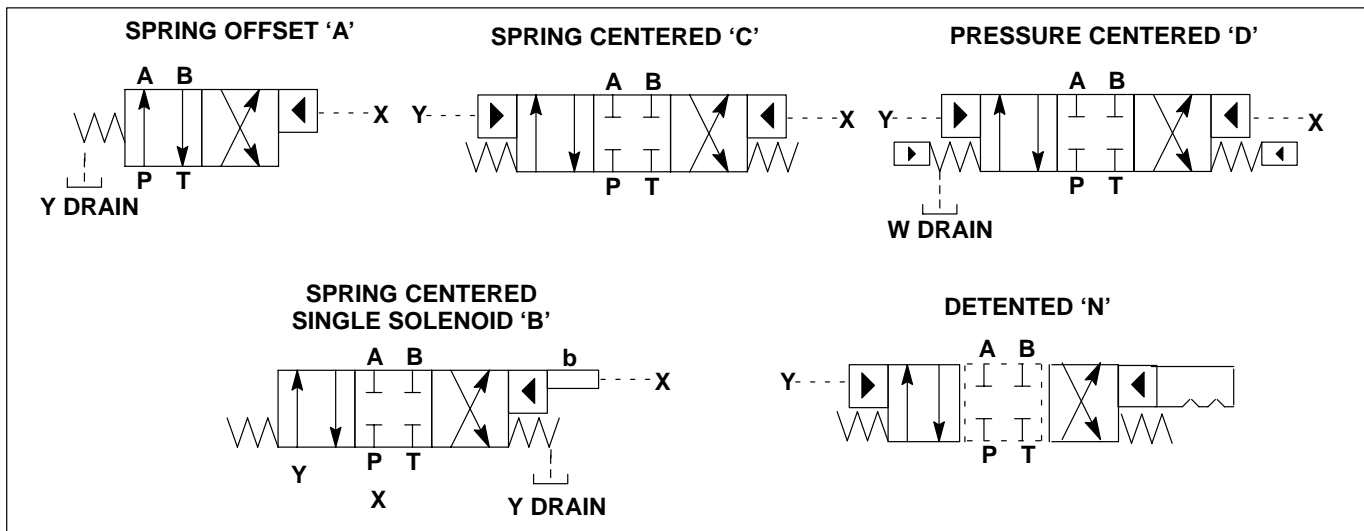

Pressure Drop

Pressure Drop

The following table lists the appropriate pressure drop curve between ports for each spool type. Use the following example to determine pressure drop for a selected spool.

Example: Find the pressure drop from P→B for type 7 spool. Using the table find numeral 7 in the spool type column. To the right of numeral 7 find the reference curve 5 (from pressure drop curve chart at bottom of page) under P→B column.

The pressure drop from P→B for type 7 spool would be obtained on curve 5.

Spool Type	Pressure Drop Curve Number				
	P→A	B→T	P→B	A→T	P→T On Center
0	5	5	5	6	4
1	2	2	5	6	7
2	1	2	1	1	–
3	2	2	5	1	–
4	7	9	7	9	8
6	1	5	1	5	–
7	5	3	5	3	–
8	3	3	3	3	6
9	1	2	1	1	–
33	1	2	1	1	–
52	3	▪	3	3	–

▪ Contact your Vickers representative.

Pressure Drop Curves

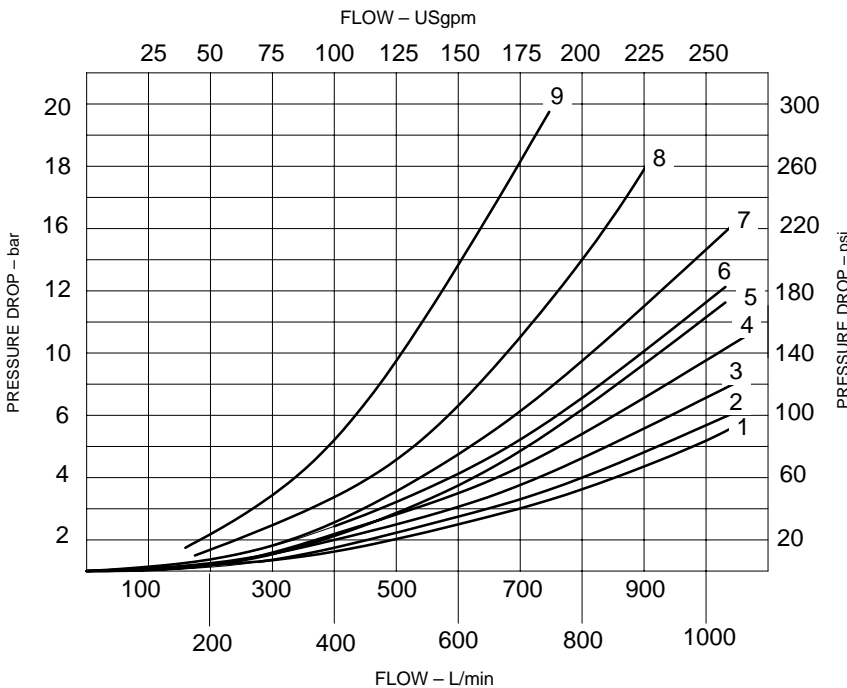

1. Figures in the pressure drop chart give approximate pressure drop (ΔP) when passing 473 l/min (125 USgpm) flow (Q) of 35 cSt (164 SUS) fluids(s) having .865 specific gravity.
2. For any other flow rate (Q_1), the pressure drop (ΔP_1) will be approximately: $\Delta P_1 = \Delta P(Q_1/Q)^2$.
3. For any other viscosity(s), the pressure drop (ΔP), will change as follows:

Viscosity								
cSt	14	32	43	54	65	76	86	
(SUS)	(75)	(150)	(200)	(250)	(300)	(350)	(400)	
% of ΔP	93	111	119	126	132	137	141	
(Approx.)								

4. For any other specific gravity (G_1)*, the pressure drop (ΔP_1) will be approximately: $\Delta P_1 = \Delta P(G_1/G)$.

Pilot Valves

Pilot Valves

General Description

Pilot valves are identified in the model code by the following letters: “S” Standard, “H” High Performance, “A” Air Gap, and “W”, “F” and “V” Wet Armature. The pilot valves can be ordered to match a variety of mainstage spool types and valve bodies.

The charts below shows ordering information for each pilot valve. For example, to order a Wet Armature pilot “W” with a spring centered mainstage “C”, use the following model code: DG4S4-012*-*

Valve Model Code: High Performance/Standard	Main Stage Spool Type	Pilot Valve Model Code
DG5V-10-H/S-(R)-*A-*	All except 4 & 8	DG4V4-3(S)-2A-*
	4 & 8 only	DG4V-3(S)-2AL-VM-*
DG5V-10-H/S-(R)-*AL-*	All except 4 & 8	DG4V-3(S)-2AL-*
	4 & 8 only	DG4V-3(S)-2A-VM-*
DG5V-10-H/S-(R)-B-*	All except 4 & 8	DG4V-3(S)-6B-*
	4 & 8 only	DG4V-3(S)-6BL-VM-*
DG5V-10-H/S-(R)-*BL-*	All except 4 & 8	DG4V-3(S)-6BL-*
	4 & 8 only	DG4V-3(S)-6B-VM-*
DG5V-10-H/S-(R)-*C-*	All except 4 & 8	DG4V-3(S)-6C-*
	4 & 8 only	DG4V-3(S)-6C-VM-*
DG5V-10-H/S-(R)-*N-*	All except 4 & 8	DG4V-3(S)-6N-*
	4 & 8 only	DG4V-3(S)-6N-VM-*

Valve Model Code: Air Gap/Wet Armature	Main Stage Spool Type	Pilot Valve Model Code		
		A/W	F	V
DG5V-10-A/W-(R)-*A-*	All except 4 & 8	DG4S4-012A-*	DG4V4-012A-*	DG4V5-2A-*
	4 & 8 only	DG4S4-0128A-*	DG4V4-012AL-VM-*	DG4V5-2AL-VM-*
DG5V-10-A/W-(R)-AL-*	All except 4 & 8	DG4S4-012AL-*	DG4V4-012AL-*	DG4V5-2AL-*
	4 & 8 only	DG4S4-0128AL-*	DG4V4-012A-VM-*	DG4V5-2A-VM-*
DG5V-10-A/W-(R)-B-*	All except 4 & 8	DG4S4-016B-*	DG4V4-016B-*	DG4V5-6B-*
	4 & 8 only	DG4S4-0168B-*	DG4V4-016BL-VM-*	DG4V5-6BL-VM-*
DG5V-10-A/W-(R)-*BL-*	All except 4 & 8	DG4S4-016BL-*	DG4V4-016BL-*	DG4V5-6BL-*
	4 & 8 only	DG4S4-0168BL-*	DG4V4-016B-VM-*	DG4V5-6B-VM-*
DG5V-10-A/W-(R)-*C-*	All except 4 & 8	DG4S4-016C-*	DG4V4-016C-*	DG4V5-6C-*
	4 & 8 only	DG4S4-0168C-*	DG4V4-016C-VM-*	DG4V5-6C-VM-*
DG5V-10-A/W-(R)-*N-*	All except 4 & 8	DG4S4-012N-*	DG4V4-016N-*	DG4V5-6N-*

Installation Dimensions

DG5V-102C-WB-10 Double Solenoid Detented & Spring Centered Models

Weight: 45,4 kg (100 lbs.)

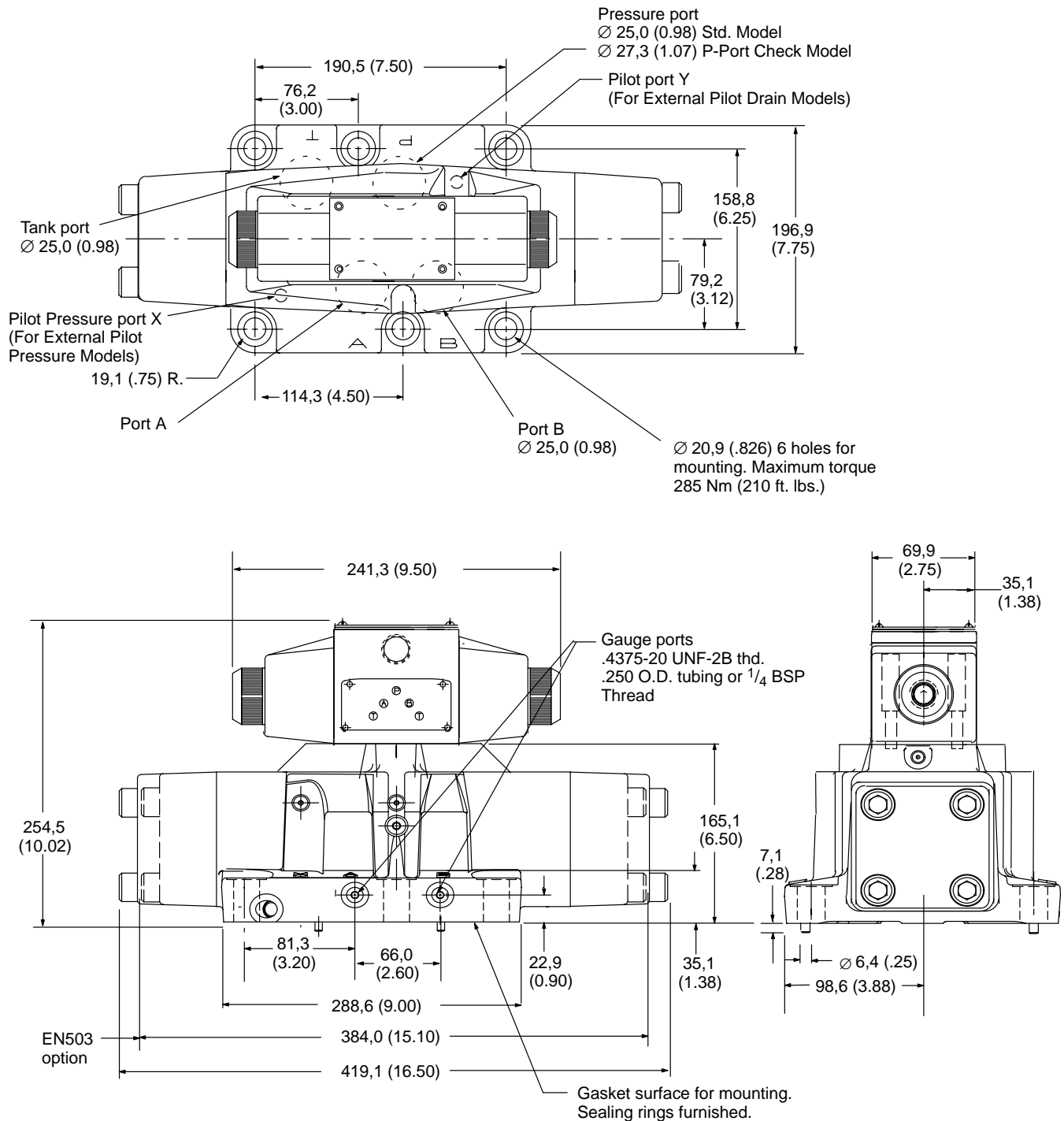

DG5V-10-A/W/F/V-**
Spring Centered Stroke Adjust
Models
 Millimeters (inches)

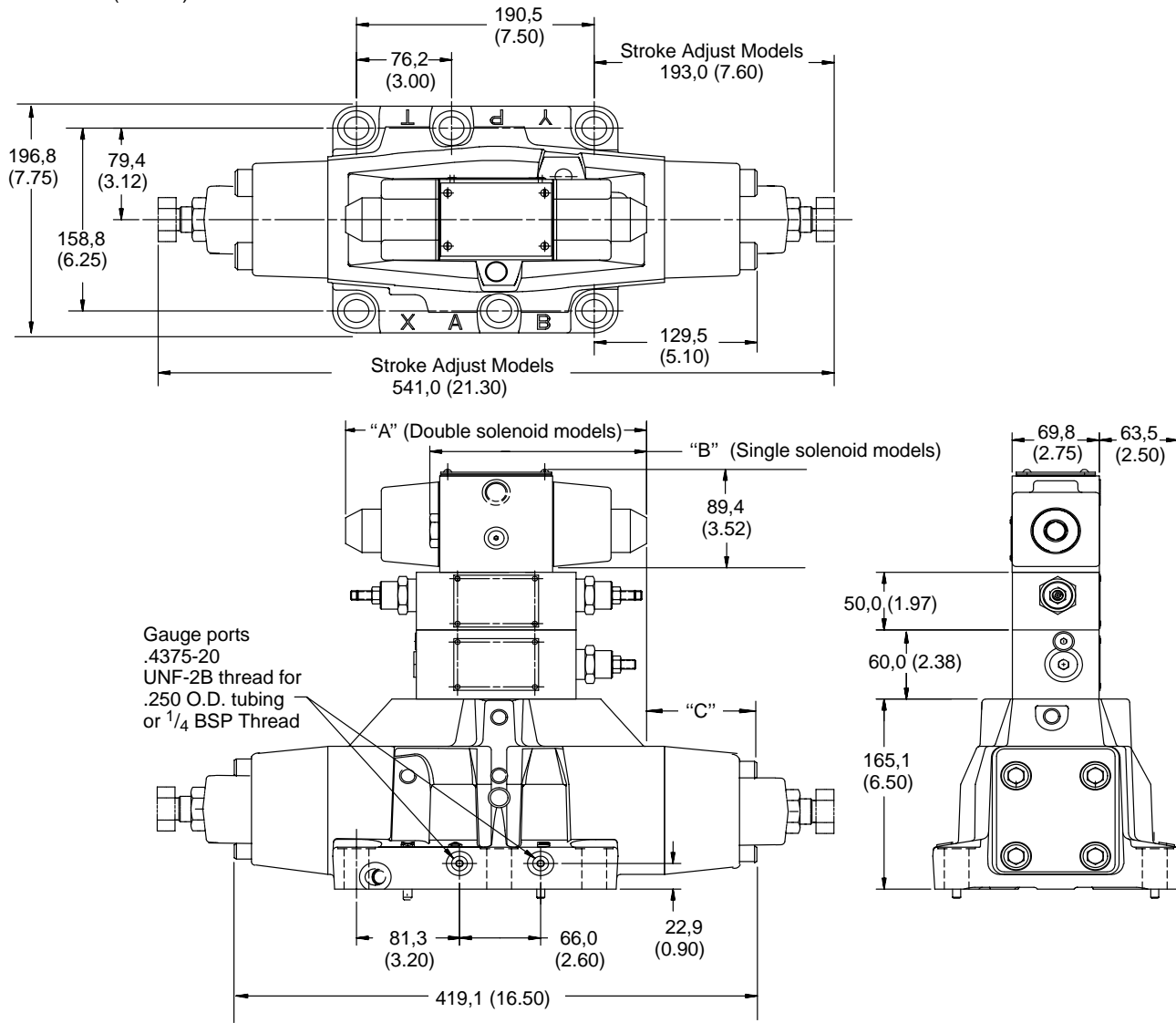

Installation Dimension Table

"A" Dimension				"B" Dimension				"C" Dimension			
"A" Pilot Valve		"W" Pilot Valve		"A" Pilot Valve		"W" Pilot Valve		"A" Pilot Valve		"W" Pilot Valve	
"AC"	"DC"	"AC"	"DC"	"AC"	"DC"	"AC"	"DC"	"AC"	"DC"	"AC"	"DC"
261,9 (10.31)	306,3 (12.06)	241,2 (9.50)	318,4 (12.54)	187,5 (7.38)	209,8 (8.25)	173,8 (6.84)	212,4 (8.36)	78,3 (3.08)	56,2 (2.21)	88,4 (3.48)	51,8 (2.04)

DG5V-10-H/S-(R)-**
Spring Centered Models

Millimeters (inches)

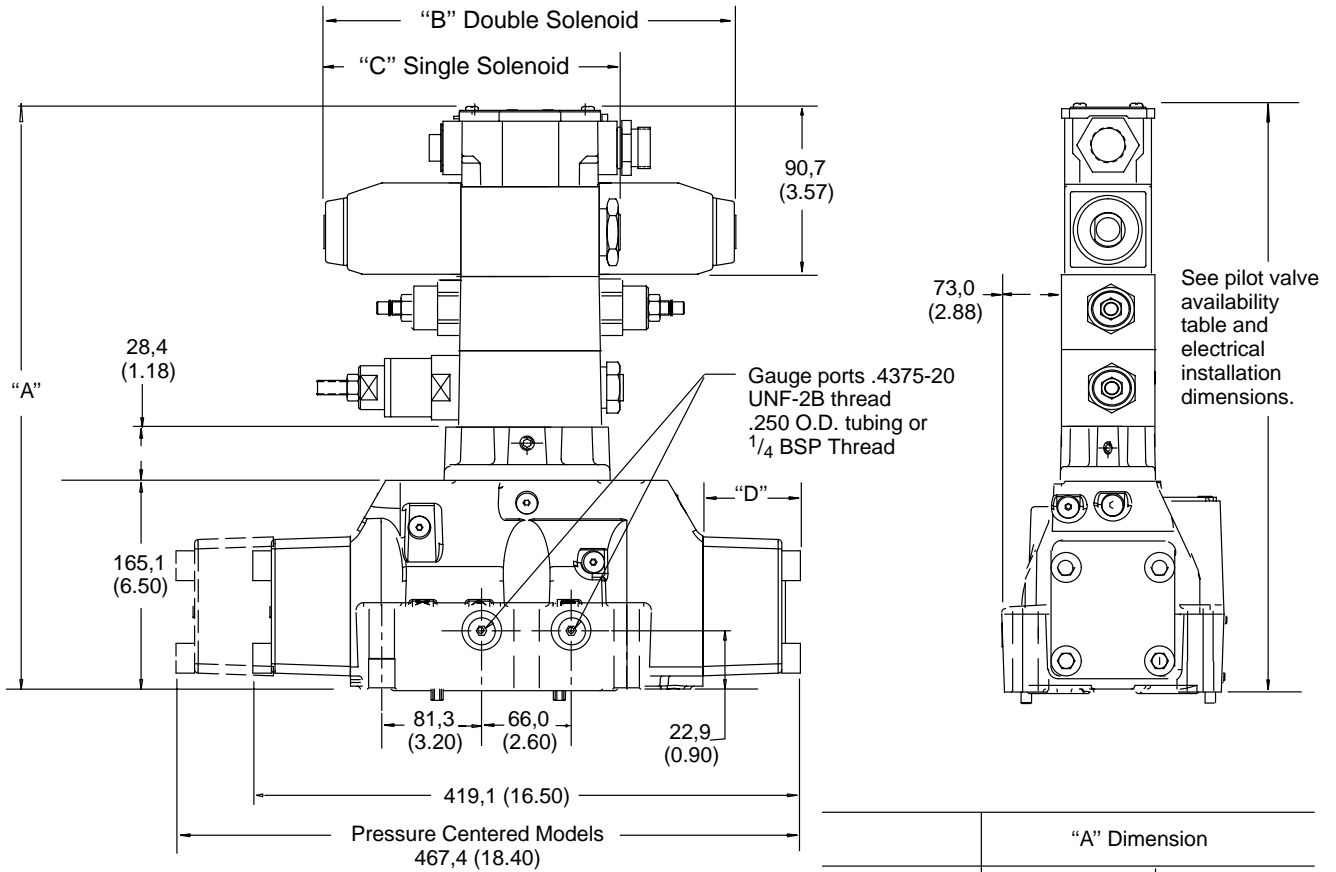
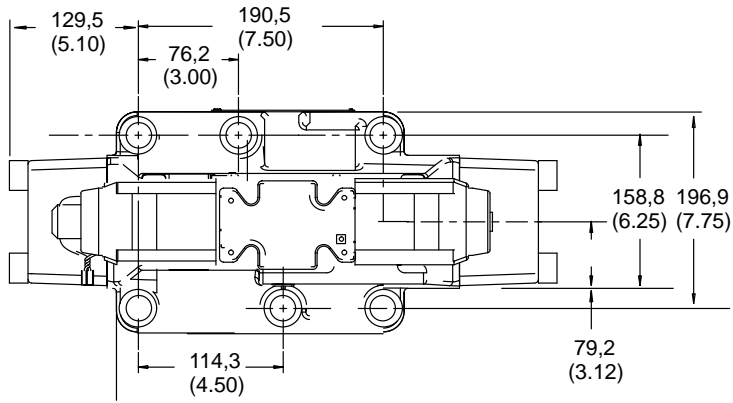

"B" Dimension		"C" Dimension		"D" Dimension	
"AC"	"DC"	"AC"	"DC"	"AC"	"DC"
200,0 (7.87)	220,0 (8.66)	146,0 (5.75)	156,0 (6.14)	107,8 (4.24)	97,8 (3.85)

	"A" Dimension	
	"A" or "W" Pilot Valve	"H" or "S" Pilot Valve
Pilot Only	254.5 (10.02)	286.8 (11.29)
Pilot & Choke	304.5 (11.99)	326.9 (12.87)
Pilot & Reducer	314.5 (12.38)	
Pilot, Choke & Reducer	364.5 (14.35)	367.0 (14.45)

DG4V4-Pilot Valves

Standard Conduit Box & 'PB' Insta-plug

Electrical Current
Signal Light ("Lights" & "PB")
2 places Sol. A Light

46,8 (1.84) AC
87,4 (3.44) DC

← Clearance Required
for Coil Removal
(Both Ends)

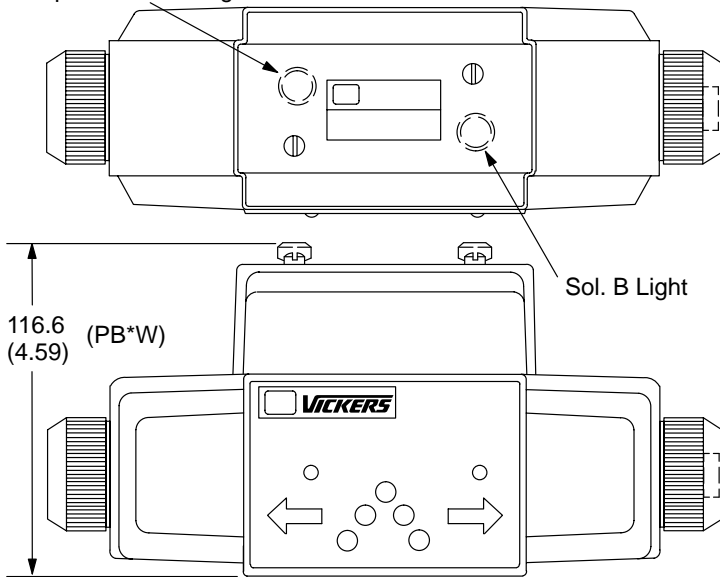

"G" - BSP
"J" - 20mm thread
"W" - 1/2" NPT
Connection Box
May be rotated 180°

Manual Operating
Pin (Both Ends)

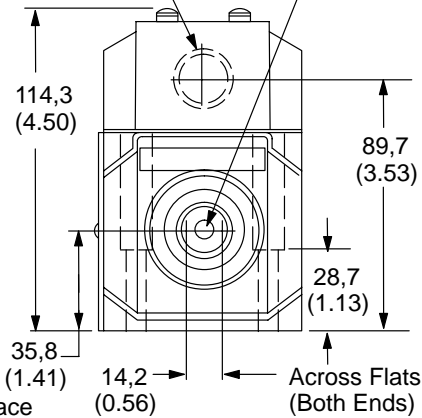

4-Valve Mounting Holes
For Socket Head Cap Screws
1/4-20x1-1/2 or M6x40 Metric
SAE Grade 8 or Better, Metric Grade 10.9
Torque 12-15 N.m (110-130 lb. in.)

NFPA D02 Mounting Surface
(ISO 4401-AC-05-4-A)

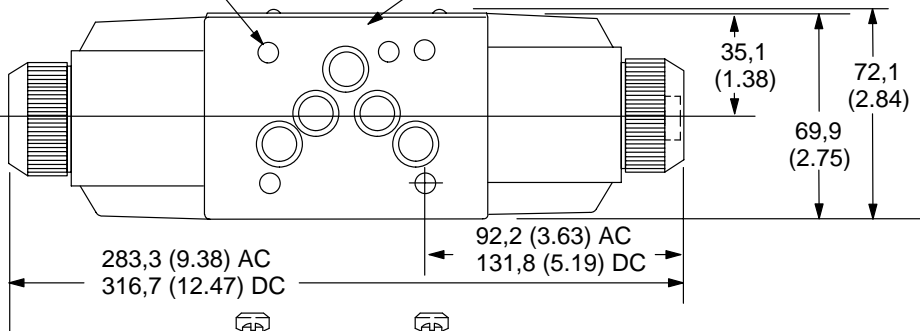

S3, S4 Switch

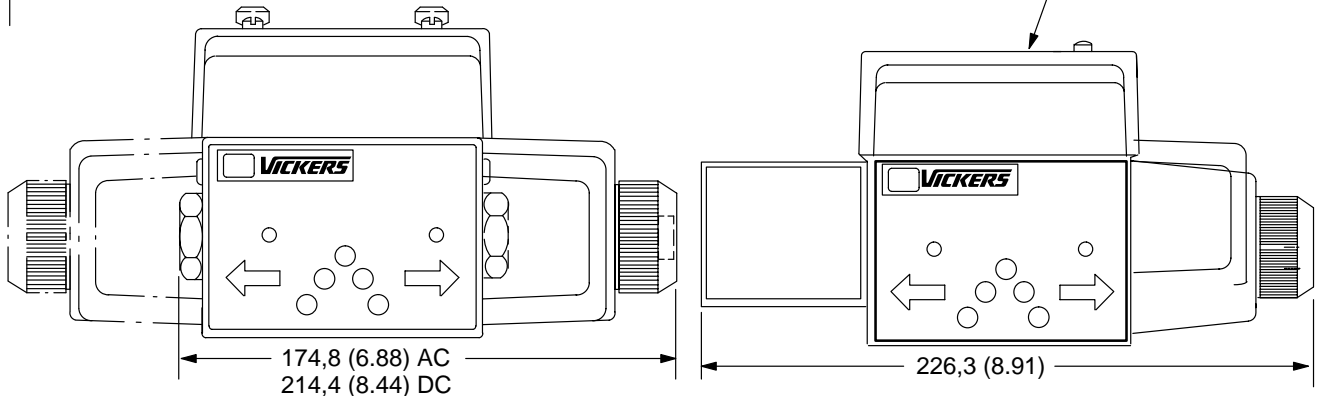

DG4V5-Pilot Valves

AC Solenoid Models

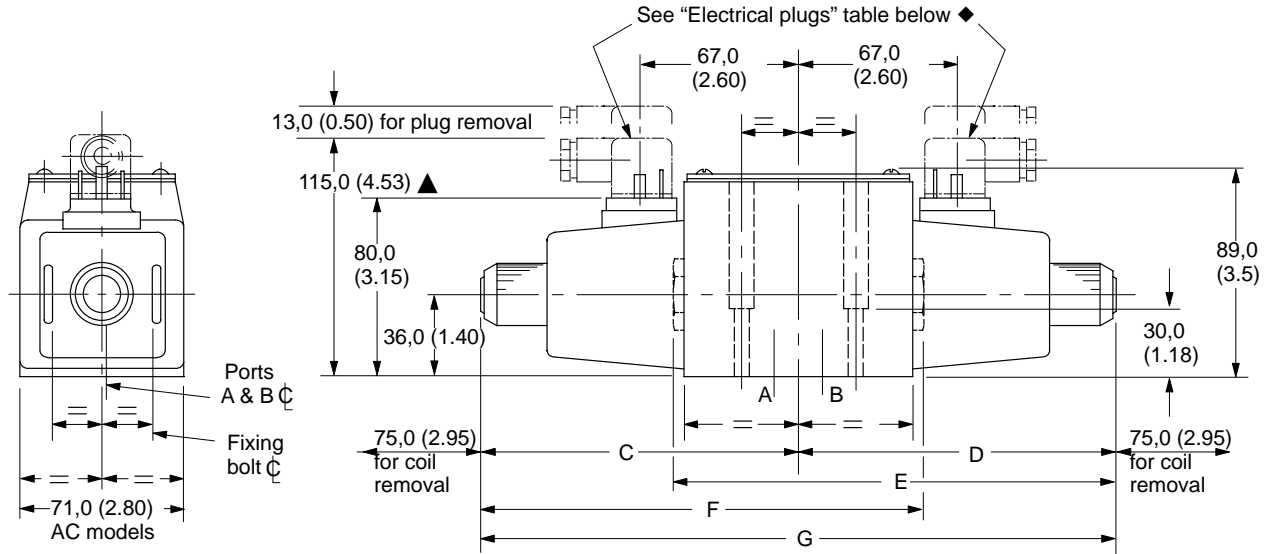

- ▲ May vary according to plug source.
- ◆ The cable entry can be repositioned at 90° intervals from the position shown. This is done by reassembling the contact holder into the appropriate position inside the plug housing.

Model	Solenoid at:	C	D	E	F	G
DG4V-5-*A(L)/B(L)(-Z)-(V)M	Port A end Port B end	123 (4.84) -	- 123 (4.84)	- 182 (7.17)	182 (7.17) -	- -
DG4V-5-*A(L)/B(L)-H2-(V)M	Port A end Port B end	138 (5.43) -	- 138 (5.43)	- 223 (8.78)	223 (8.78) -	- -
DG4V-5-*A(L)/B(L)-P-(V)M	Port A end Port B end	123 (4.84) -	- 123 (4.84)	- 195 (7.68)	195 (7.68) -	- -
DG4V-5-*C/N(-Z)-(V)M	Both ends	123 (4.84)	123 (4.84)	-	-	246 (9.68)
DG4V-5-*C/N-H-(V)M	Both ends	138 (5.43)	138 (5.43)	-	-	276 (10.87)

Electrical plug(s) (without indicator light) to DIN 43650.
Must be ordered separately by part number(s).

Part No.	Color	Solenoid identity marked	Cable gland
710775	Black	B	Ø6-10 mm
710776	Gray	A	

DG4V5-Pilot Valves

DC Solenoid Models

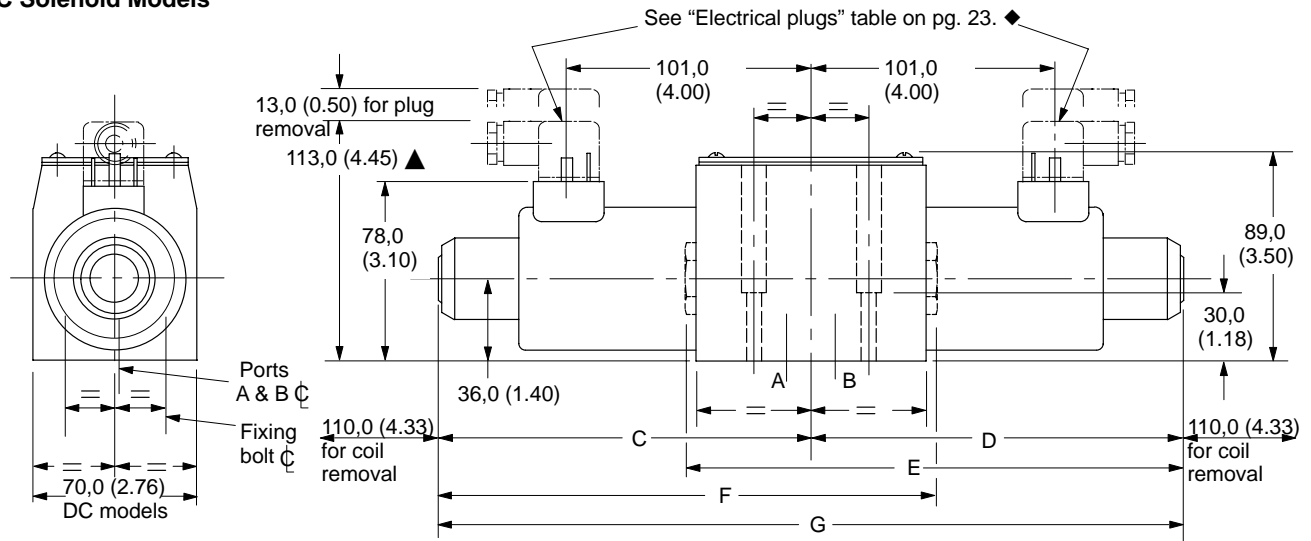

▲ May vary according to plug source.

◆ The cable entry can be repositioned at 90° intervals from the position shown. This is done by reassembling the contact holder into the appropriate position inside the plug housing.

Model	Solenoid at:	C	D	E	F	G
DG4V-5-*A(L)/B(L)-(-Z)-(V)M	Port A end Port B end	156 (6.14) -	- 156 (6.14)	- 215 (8.46)	215 (8.46) -	- -
DG4V-5-*A(L)/B(L)-H2-(V)M	Port A end Port B end	185 (7.28) -	- 185 (7.28)	- 270 (10.63)	270 (10.63) -	- -
DG4V-5-*A(L)/B(L)-P-(V)M	Port A end Port B end	156 (6.14) -	- 156 (6.14)	- 228 (8.98)	228 (8.98) -	- -
DG4V-5-*C/N(-Z)-(V)M	Both ends	156 (6.14)	156 (6.14)	-	-	312 (12.28)
DG4V-5-*C/N-H-(V)M	Both ends	185 (7.28)	185 (7.28)	-	-	370 (14.57)

Optional Features

Millimeters (inches)

Reducer Module DGMX2-5-PP-FW-S-30-EN406

The reducer module is required for Air Gap and Wet Armature piloted models when pilot pressure exceeds 210 bar (3000 psi). These two-stage spool valves maintain a reduced outlet pressure against variations in inlet pressure. These valves are able to act as relief valves (at 50% of the maximum flow) to prevent excess pressure being developed when an actuator is subject to a reactive load.

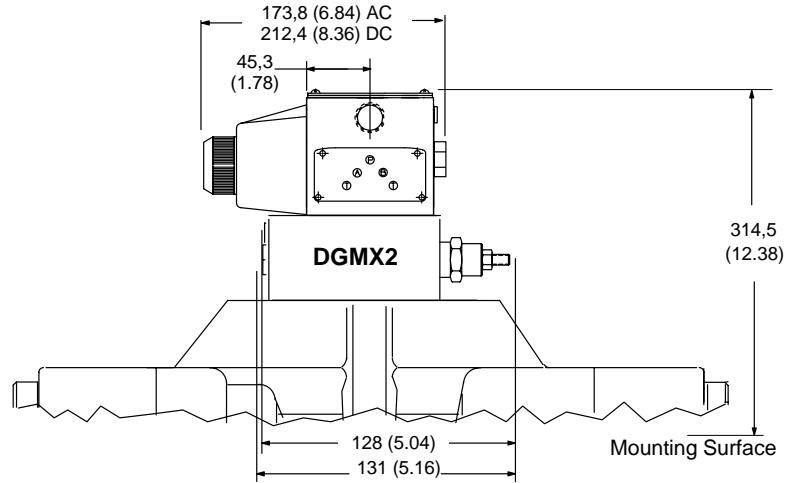

Pilot Choke DGFMN-5-Y-A1W-B1W-30

Pilot choke increases the amount of time to shift the mainstage spool, lowering the possibility of large flow transients in the circuit. It is adjusted by backing off locknuts and turning adjusting screws inward to decrease rate of spool travel and outward to increase spool travel rate. See spool control modifications in model code.

Stroke Adjustment

Stroke adjustment limits movement of the mainstage spool for smoother flow. Backing off the locknut and turning the adjusting screw inward (clockwise) decreases spool stroke. See spool control modifications in model code.

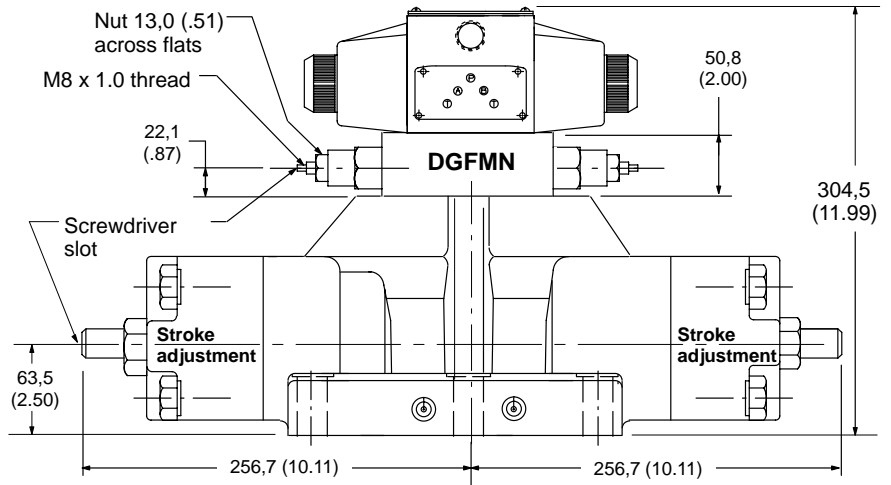

Pilot Valve Port Orifices

These can be used for restricting flow or for circuit dampening. Orifice plugs create a pressure drop which increases flow. These plugs can be used in ports P, T, A, or B and are used in conjunction with each of four different check valves.

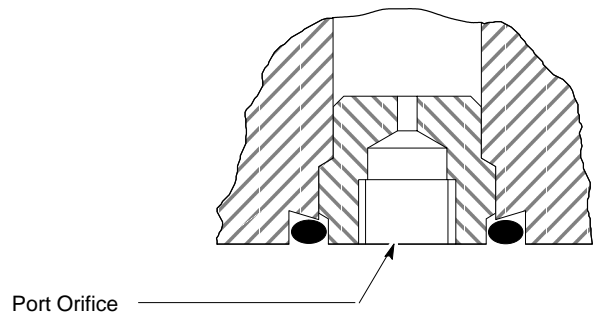

DG5V-10-*-D

Pressure Centered Pilot Operated Models

This option provides faster spring centering time by using pilot pressure to center the spool. The centering springs are used in addition to pilot pressure to ensure positive centering of the spool. The valve spool is returned to center position by pilot pressure and centering springs. If pilot pressure fails or falls below the required minimum, the spool will return to center position at minimum pilot pressure flow rates for pressure centered valves.

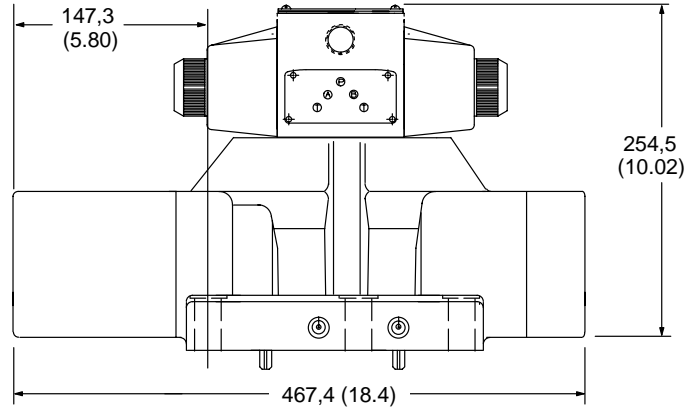

Integral Check Valves

For internal pilot pressure, an integral pressure port check valve is required for internally piloted valves with open center spools (0,1,4,8 & 9). The pilot pressure generated is the total of: P→T drop through the valve in center condition, the pressure drop through the check valve, plus the pressure at the tank port.

For proper operation, the total pressure drop must be greater than the minimum required pilot pressure (see chart). To prevent load drop, a check valve in the pressure port can be used to prevent reverse flow from "A" cylinder port to pressure port. If using as reverse flow check, maximum reverse pressure is limited to 210 bar (3000 psi).

X - Fast Response

Use of this option decreases the shift time and increases the system shock generation. This requires the removal of an orifice plug within the mainstage body. It is available on all models except Pressure Centered "D", "DB", or CETOP 3 piloted models by adding "X" to the model code. Example: DG5V-2C-X-*-10.

Pressure Drop Across Check Valve

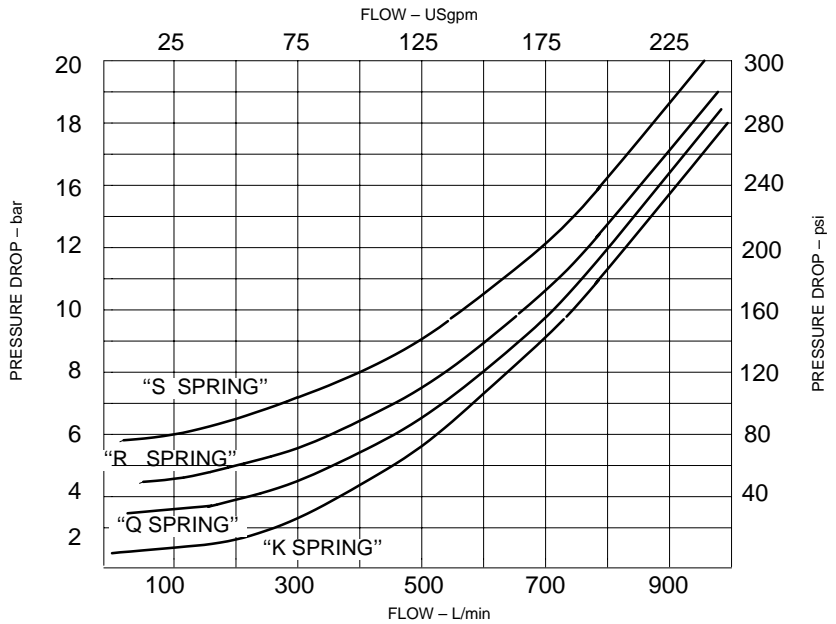

Electrical Information

Typical Solenoid Energizing

Solenoids identified to U.S. standards

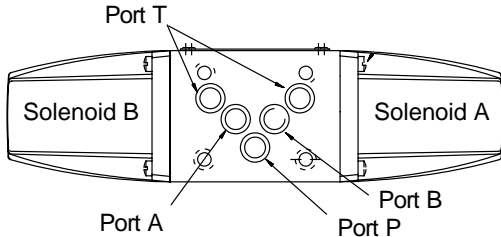

Functional symbols related to solenoid identity "A" and/or "B" according to NFPA/ANSI standards, i.e. energizing solenoid "A" gives flow P→A, solenoid "B" gives flow P→B (as applicable).

Solenoids identified to European standards (specify "V" in model code)

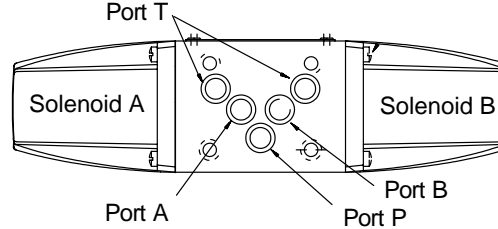

Functional symbols related to solenoid identity "A" and/or "B" according to European convention i.e. solenoid "A" adjacent to "A" port, solenoid "B" adjacent to "B" port of valve.

DG4S4-01 Air Gap Solenoids

Solenoid Identification Letter	Solenoid Voltage Rating	Inrush Amps (rms)	Holding Amps (rms)	Holding Watts
A	115V AC 60 Hz	5.1	0.61	-
B	115V AC 50/60 Hz	(50) 3.25 (60) 4.97	(50) .56 (60) .59	
D	230V AC 60 Hz	2.55	.32	
EM	460V AC 60 Hz	1.27	.16	
F	6V DC	-	-	
G	12V DC			24
H	24V DC			24

DG4S4-01 Wet Armature Solenoids

Solenoid Identification Letter	Solenoid Voltage Rating	Inrush Amps (rms)	Holding Amps (rms)	Holding Watts
B	120V AC 60 Hz	3.80	0.69	35
	110V AC 50 Hz	4.10	0.85	33
D	240V AC 60 Hz	2.10	0.34	36
	220V AC 50 Hz	2.30	0.45	34
ED	240V AC 50 Hz	1.85	0.27	28
A	110V AC 50 Hz	3.80	0.63	29
C	220V AC 50 Hz	2.00	0.30	28
G	12V DC	-	3.67	44
H	24V DC		1.83	44
J	48V DC		0.92	44
X	250V DC		0.17	44
DP	125V DC		0.35	44

DG4V4-01 Wet Armature Solenoids (F)

Standard			
Solenoid Voltage Rating	Inrush Amps (rms)	Holding Amps (rms)	Holding Watts
120V AC 60 Hz	3.95	0.98	37
110V AC 50 Hz	4.10	0.98	37
240V AC 60 Hz	1.97	0.49	37
220V AC 50 Hz	1.77	0.49	36
110V AC 50 Hz	3.25	0.77	30
220V AC 50 Hz	1.55	0.42	28
240V AC 50 Hz	1.55	0.42	28
12V DC	-	3.64	45
24V DC		1.83	45
Low Power			
120V AC 60 Hz	2.40	0.69	27.5
110V AC 50 Hz	2.40	0.78	28.5
240V AC 60 Hz	1.15	0.25	27.5
220V AC 50 Hz	1.10	0.35	28.5
110V AC 50 Hz	2.40	0.61	23
220V AC 50 Hz	1.00	0.24	23
240V AC 50 Hz	1.20	0.26	23
12V DC	-	2.33	33
24V DC		1.25	30

DG4V5 Wet Armature Solenoids (V) AC Solenoids

Solenoid Voltage Rating	Inrush Amps (rms)	Holding Amps (rms)	Holding Watts
AC 50 Hz	700▲	375▼	105
AC 60 Hz	750▲	440▼	130

▲ Armature fully retracted, 1st half-cycle

▼ At start of normal working stroke of valve spool.

DC Solenoids

At rated voltage and wire temperature of
20°C (68°F):

Type HL 32W

Others 38-42W

DG4V-3(S) Standard Performance Solenoids Coil Ratings

Solenoid Identification Letter	Solenoid Voltage Rating
A	110V AC 50 Hz
B	110V AC 50 Hz 120V AC 60 Hz
C	220V AC 50 Hz
D	220V AC 50 Hz 240V AC 60 Hz
G	12V DC
H	24V DC

DG4V-3 High Performance Solenoid Coil Ratings
(low power coils)

Solenoid Identification Letter	Solenoid Voltage Rating
BL	110V AC 50 Hz 120V AC 60 Hz
DL	220V AC 50 Hz 240V AC 60 Hz
GL	12V DC
HL	24V DC

Power consumption, AC solenoids (for coils listed in model code).	Initial▲ VA (RMS)	Holding VA (RMS)	Initial▲ VA (RMS)	Holding VA (RMS)
Full power coils:				
Single frequency coils AC 50 Hz	225	39	265	54
Dual frequency coils at 50 Hz	265	49	280	61
Dual frequency coils at 60 Hz	260	48	300	58
Low power coils, "BL" and "DL":				
Dual frequency coils at 50 Hz	Low power coils not usable with DG4V-3S valves.		170	37
Dual frequency coils at 60 Hz			190	37

Power consumption, DC solenoids at rated voltage and 20°C (68°F).				
Full power coils:				
12V, model type "G"	30W	–	30W	–
24V, model type "H"	30W	–	30W	–
Low power coils:				
12V, model type "GL"	Low power coils not usable with DG4V-3S valves.		18W	–
24V, model type "HL"			18W	–

▲ 1st half cycle; armature fully retracted.

DIN Standard 43650 Plug-in Connectors

Plug Connector

(Order separately)
(ISO 4400/DIN 43650)

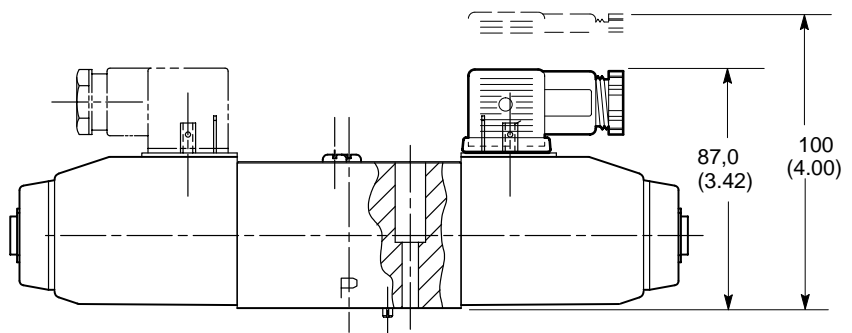

DG4V4 Electrical Plugs & Connectors

'L' Low Power Option

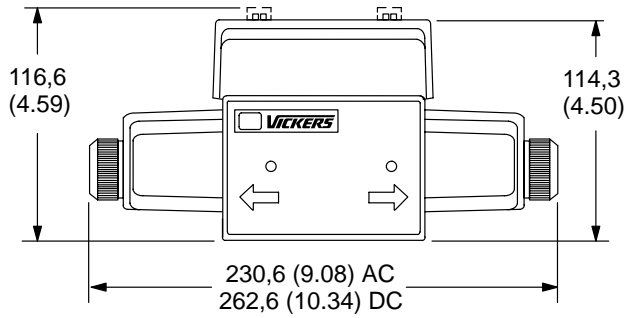

'U' DIN 43650 Connector* Option

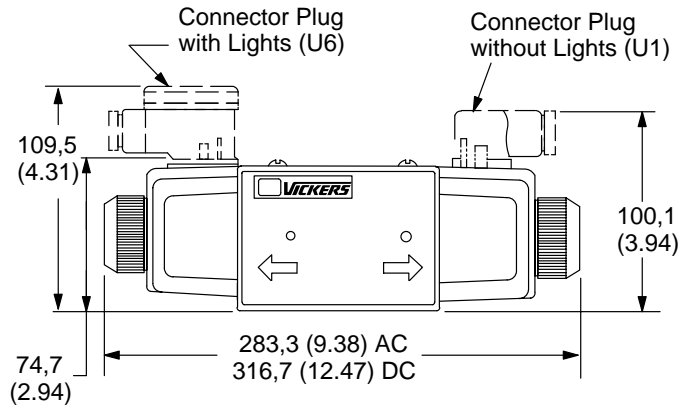

*Connector Plug not included with valve

'PA'

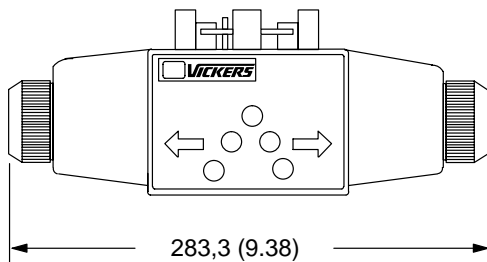

Connector Option, Pin Type

'PA3'/'PA5' (NFPA T 3.5.29)

PM4 (SAE H1738-2)

Single Solenoid Valve (PA3)

Double Solenoid Valve or Optional Single Solenoid Valve (PA5)

Double Solenoid Valve (PM4)

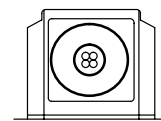
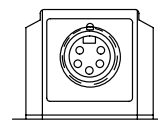
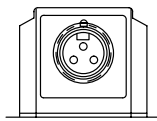

Number of Solenoids	Number of pins	Option Code
Single	3	PA3
Single or Double	5	PA5
Double	4	PM4

Position Switch

DG4V3(S)-A-*S6-U-*-60

Single solenoid models with LVDT type switch indicating when the spool is in the spring off-set position. ISO 4400 (DIN 43650) connection to solenoid; Pg7 connection to switch.

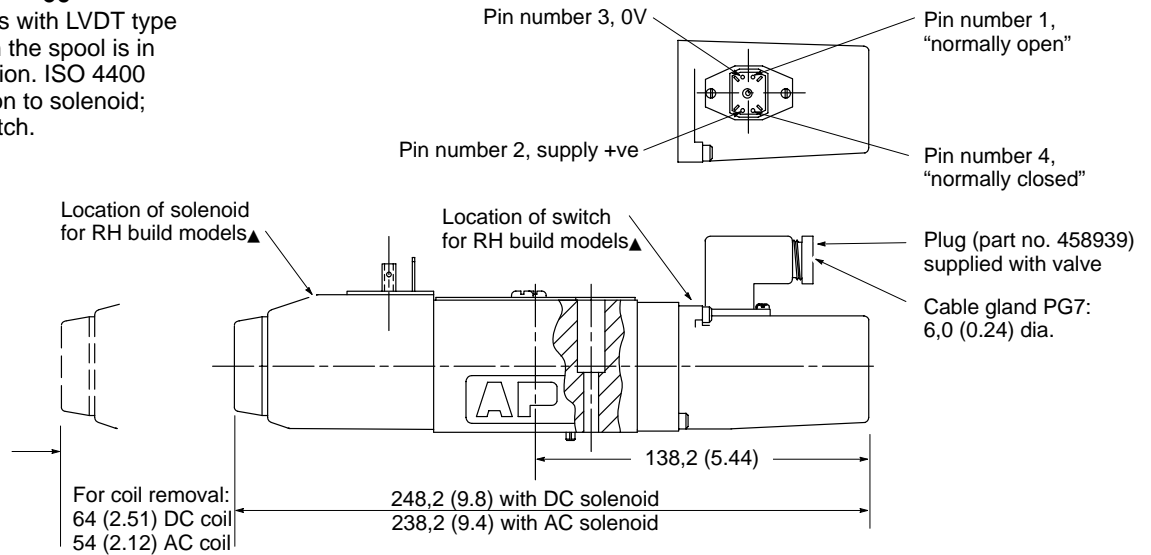

▲ For LH build (DG4V-3-*AL) solenoid and switch locations are reversed.

Limit Switch

DG4V-3(S)-A-*S3-FPAW-*2-60

DG4V-3(S)-A-*S4-FPAW-*2-60

DG4V-3(S)-A-*S5-F-*2-60

Single solenoid models with mechanical type switch monitoring of spool movement. Conduit box with leads, or pre-wired to NFPA T3.5.29-1980 receptacle.

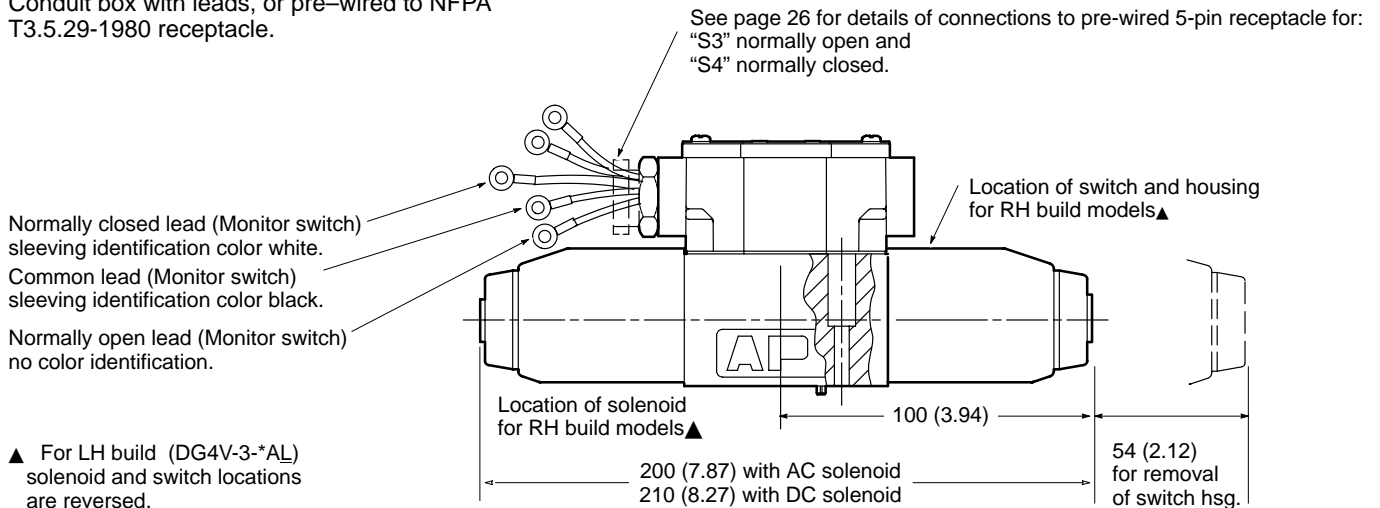

▲ For LH build (DG4V-3-*AL) solenoid and switch locations are reversed.

Insta-Plug Option

The insta-plug consists of the following features:

1. Section "A", a four-pronged self-aligning electrical plug. It is secured in a housing that is mounted on top center of the valve body where the solenoid leads terminate; or:
2. Section "B", a complete insta-plug assembly that includes the "A" housing on top which rests on a similar housing containing the mating receptacle. The two housings are keyed to assure proper hook-up.

The top housing is removed from the lower ("A") housing to break the electrical connections to the valve solenoids, or pressed onto the "A" housing to complete the circuit. The assembly is held together by two slotted thumb screws.

The top housing is removed from the lower "A" housing to break the electrical connections to the valve solenoids or pressed onto the "A" housing to complete the circuit. The assembly is held together by two slotted thumb screws.

A nameplate and solenoid indicator lights are part of the receptacle when specified.

Connections to the electric power are made through the end of the receptacle housing and can be pre-wired by the customer. End location of electrical conduit port permits space-saving side-by-side valve mounting.

Wire leads approximately 177.8 mm (7.00") long are provided when no lights are specified. Models with lights have terminals inside the receptacle housing.

After initial installation, electrical and hydraulic connections need not be disturbed when valve with insta-plug is removed.

Note

Solenoids "A" and "B" are identified on the plug-in and receptacle housing; they correspond with solenoid identification plate. In case of tandem valves (#8 spool and LH models), the insta-plug is rotated 180° and conduit connection is on the opposite end.

Insta-Plug

DG4V-3(S)---FPA---60
DG4V-3(S)---FPBW---60

Vickers 2-part "Insta-Plug" eliminates breaking electrical inputs for valve disconnect. A male half is pre-wired to the valve body. The mating plug is inside a wire housing with external terminals for machine wire connections.

PA configuration

Dim mm (in.)

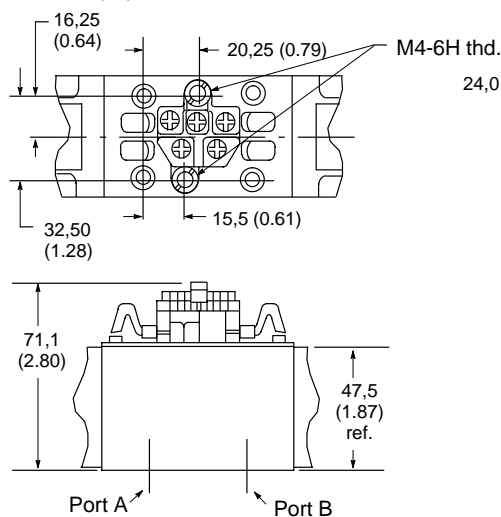

PBW configuration

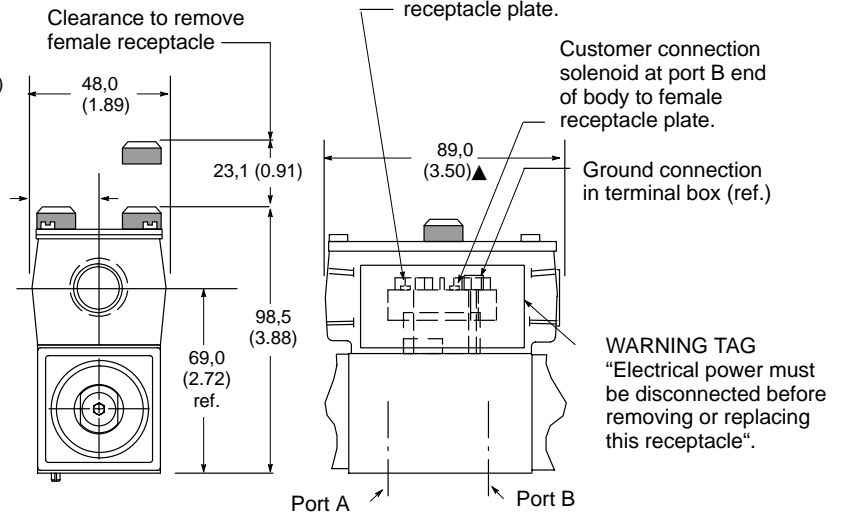

▲ The conduit box dimensions used for the PA/PBW type connector are different from those on the other "F" type coil models.

Wiring Housing - Lights for DG4S4-01-60 Valves

The electrical accessories options are available on the basic DG4S4-01-* directional control and all valves that use the DG4S4-01* as pilot valve. An electrical wiring diagram is provided on the bottom of the nameplate, and shown below, for installation instructions.

Lights (L)

Lights are "on" when there is voltage across the solenoids. (Only double lights are available.) Lights are available with most options. The light options have an integral terminal strip and is for use with 100 through 125 and 192 through 233 volt service solenoids only. They are not available for hazardous duty type models.

Wiring Housing (W)

The wiring housing (W) is a 39,6 (1.56) high riser block mounted on top of the pilot valve. A 1/2" NPTF thread connection is provided in one end of the housing. The housing can be rotated 180° if the connection is required on the opposite end. This connection will readily accept common electrical quick disconnect assemblies on the market. The wiring housing is available with most options.

Grounding

A drilled hole is provided for a #8 self tapping screw which will permit a ground wire to be secured to the pilot valve body.

Units can be series grounded if desired. The DG4S4-01 pilot valve bodies have a cast "ground" symbol adjacent to the drilled hole.

Note

Electrical accessories shown are not available with hazardous duty type models identified by model prefix "X" or "XM".

Electrical Diagram

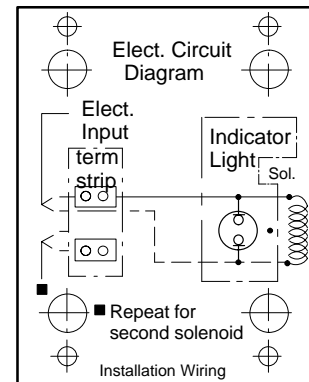

Terminal strip and lights

For valves with type "F" coils.

Dim mm (in.)

Terminal strip (part number 890345) clips to cover and can be field-fitted.

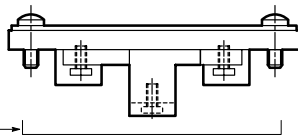

Conduit box cover and nameplate complete with sealing gasket and 4 screws.

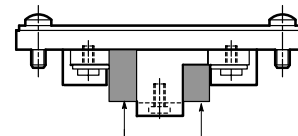

Light assembly is held in place by end pair of M3 screws; can be fitted to terminal strip.

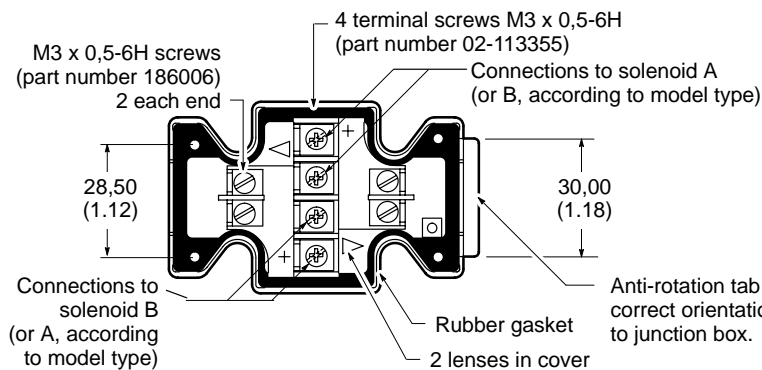

Anti-rotation tab ensures correct orientation of cover to junction box.

1. For DC coils the +ve lead(s) must be connected to the terminal(s) marked +. When using 3-wire incoming leads to double solenoid valves (i.e. common neutral) the inner pair of terminals must be interconnected.

2. For correct light indication of energized solenoid ensure that solenoid leads are correctly connected; light terminals are common with each outer pair of solenoid terminals according to the side with + mark.

Typical NFPA Hydraulic Valve Electrical Connector

The receptacle is a standard three or five pole connector with shortened leads and terminals added. The five pole plug has four leads 101,6 (4.0) long and one 177,8 (7.0) long. The three pole plug has two leads 101,6 (4.0) long and one 177,8 (7.0).

All wires have Underwriters recognized non-solder insulated eyelet terminals. The #4 and #2 leads are attached to the 'A' solenoid and the #5 and #1 leads are attached to the 'B' solenoid. The green wire is used for the ground connection (#8 screw is furnished).

NFPA Connector T3.5.29-1980

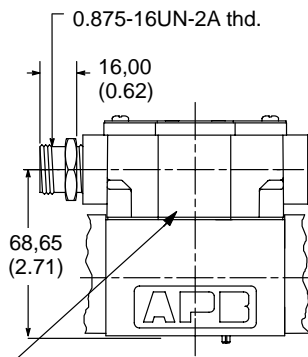

Warning tag:
"Electrical power must be disconnected before removing or replacing electrical plug."

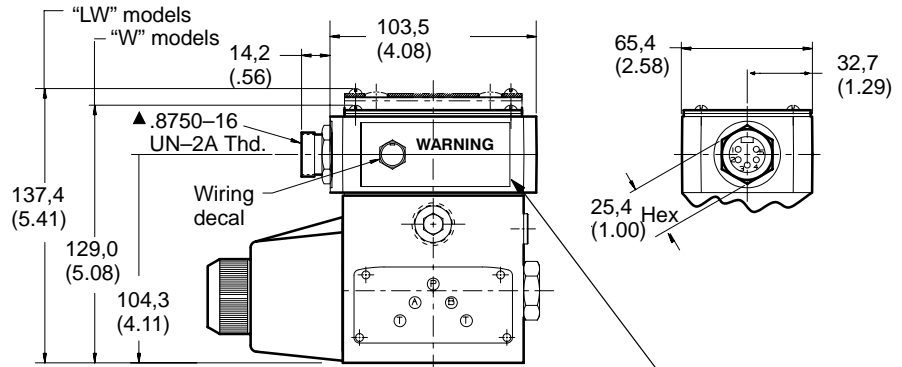

▲ Electrical connection is over solenoid on single solenoid models, and over "b" solenoid on dual solenoid models. See diagram plate for "b" solenoid location. Electrical rating 600 volts, 3 pole, 10 amps and 5 pole, 8 amps. The female portable plug to be furnished by customer.

Warning tag:
"Electrical power must be disconnected before removing or replacing electrical plug."

Typical 3- and 5- Pin Connectors

(See DG4V and DG4S pilot valve descriptions or contact your Vickers representative for model code information.)

3 pin connector

Use with single solenoid valve

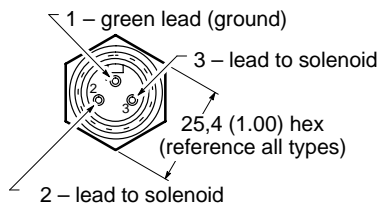

5 pin connector

Use with single solenoid valve

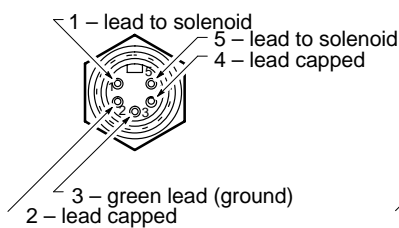

5 pin connector

Use with double solenoid valve

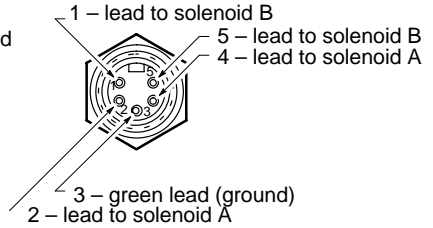

5 pin connector

Use with single solenoid valve with S3 spool position monitor switch

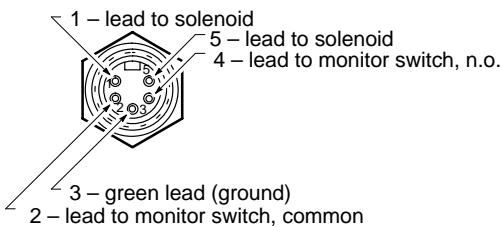

(Not available with DG4S Models)

5 pin connector

Use with single solenoid valve with S4 spool position monitor switch

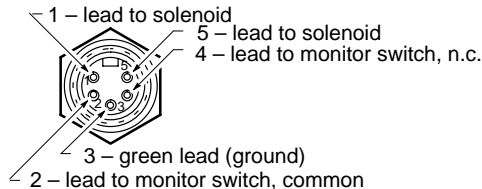

**Plug connector
(Order separately)
(ISO4400/DIN 43650)**

Cable diameter range Ø6–10 mm (0.24–0.40)
 Wire section range Ø,5–1,5 mm² (0.0008–0.0023 in²)
 Terminals Screw type
 Type of protection IEC144 class IP65, when plugs are fitted correctly to the valves with the interface seals (supplied with plugs) in place.

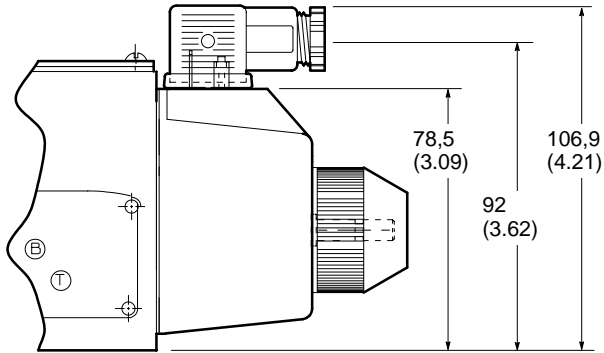

Connector can be positioned at 90° intervals on valve by re-assembling contact holder into appropriate position inside connector housing. Connectors with and without indicator lights are available (order separately).

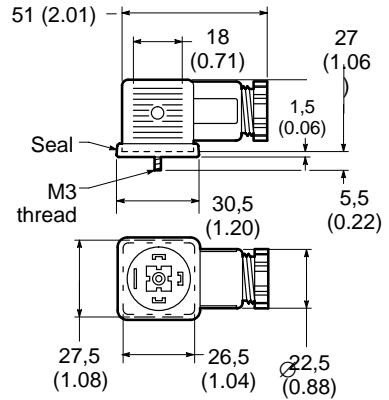

Receptacle	Voltage (AC or DC)	Gray "A" sol.	Black "B" sol.
Without lights	—	710776	710775
With lights	12-24	977467	977466
	100-125	977469	977468
	200-240	977471	977470

**Single Solenoid with Monitor Switch
SDG4S*(L)-01*A-5***

Millimeters (inches)

An integral monitor switch permits electrical interlocking of various hydraulically controlled motions without resorting to external mechanical contrivances. The switch monitors the valve spool position and may be wired into the control circuit. The monitor switch housing does not provide for manual operation.

Monitor switch data:

Plunger type

- panel mounting
- single pole
- double throw contact arrangement
- "A" normally closed
- "B" normally open

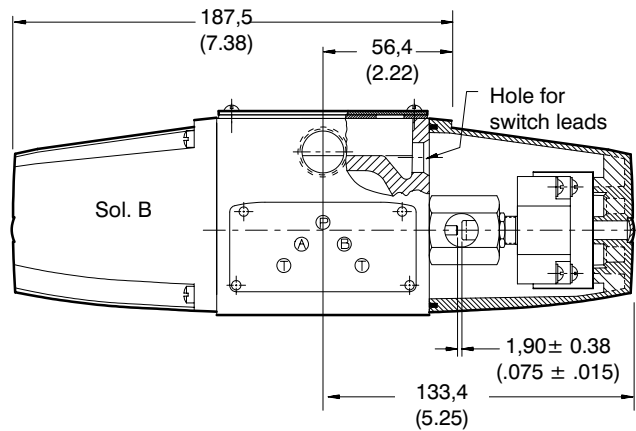

Volts	AC amp	DC amp
28	20	10
125	20	0.5
250	20	0.2
480	20	
600	5	

Lights & Wiring Housing Insta-Plug

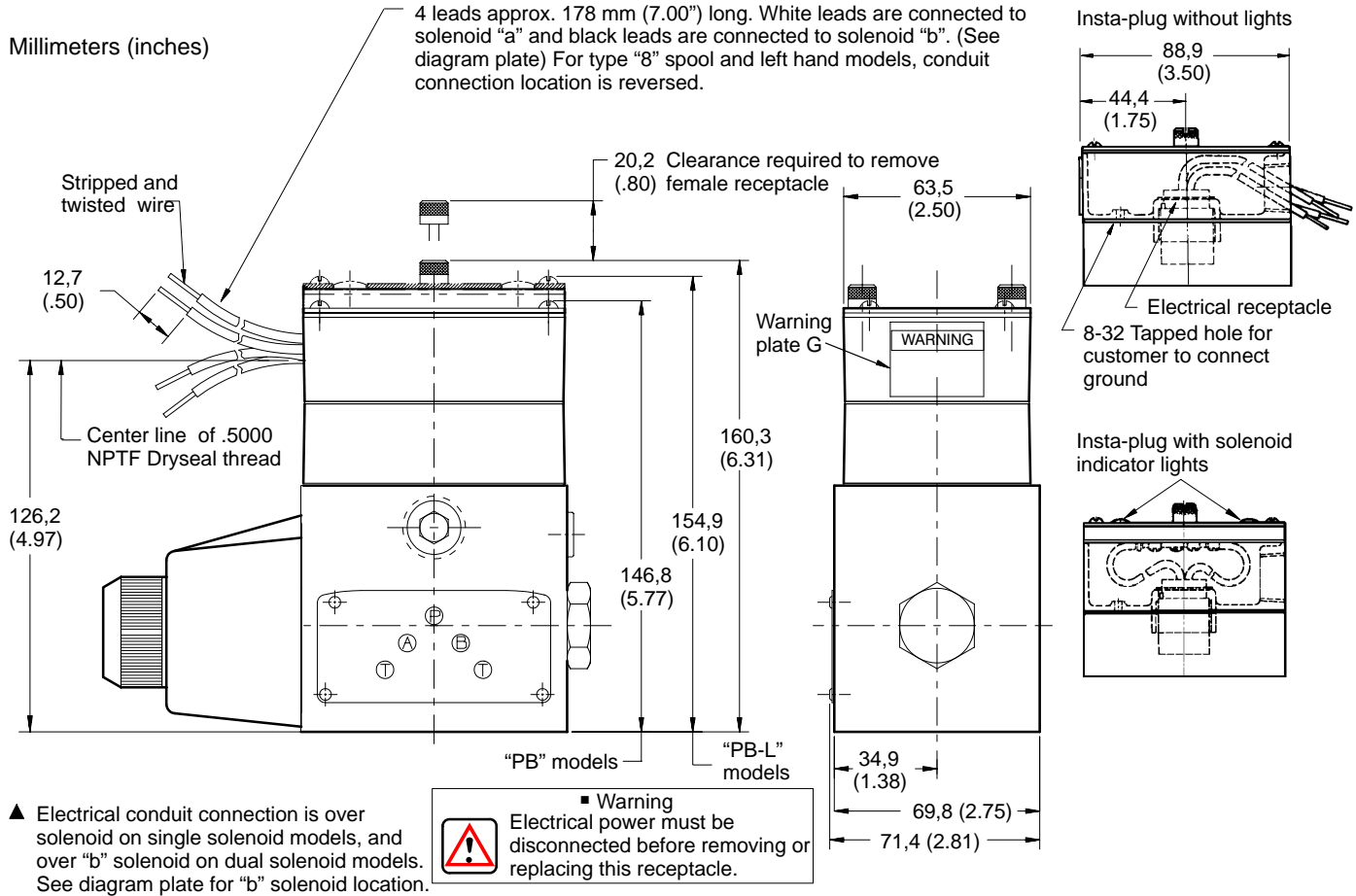

Lights & Wiring Housing W, LW Models

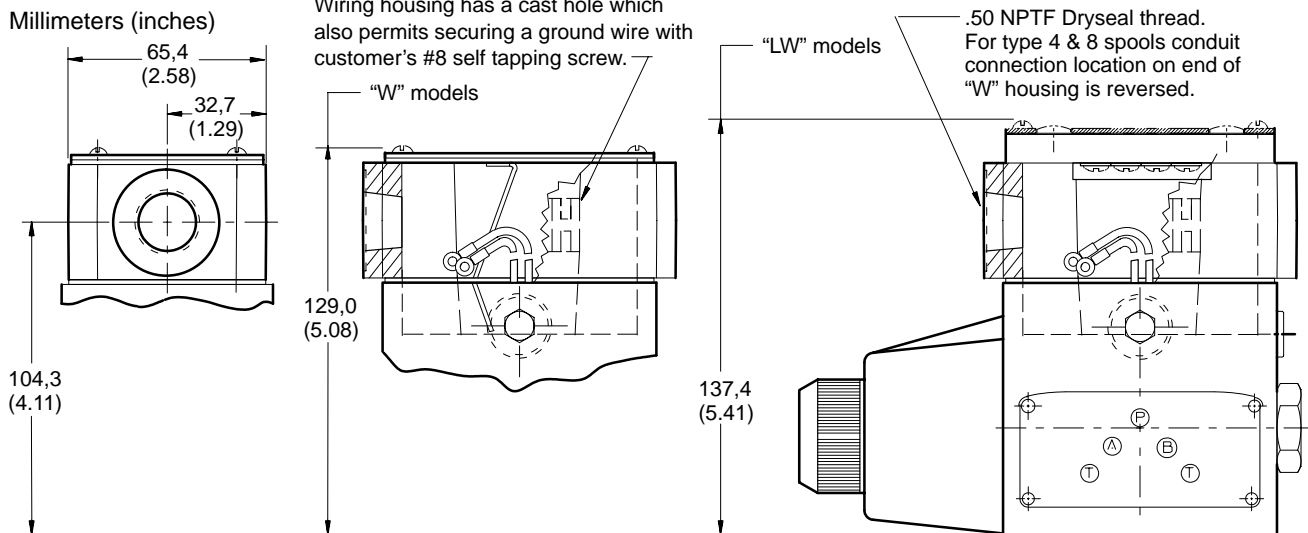

Mounting Surface

Millimeters (inches▲)

A machined pad must be provided for mounting. Pad must be flat within 0,127 mm (.0005 inch) and smooth within 1,6 µm (63 microinch). Mounting bolts, when provided by customer, should be SAE grade 7 or better.

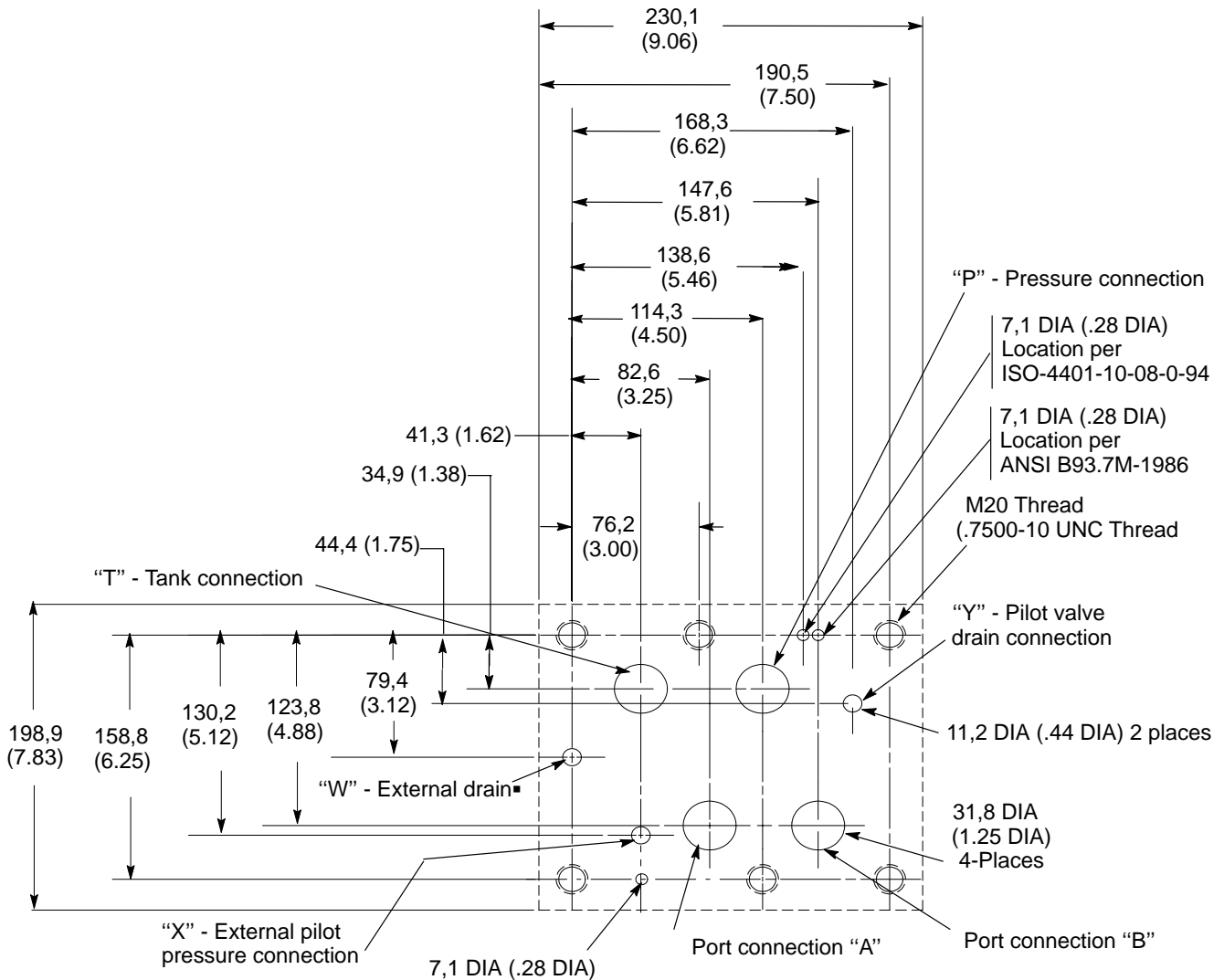

▪ Required for 'D' Pressure Centered models only

Subplates

Subplates must be ordered separately. For 210 bar (3000 psi) applications, order Subplate DGSM-10-24S-11. Subplate not available for 350 bar (5000 psi) applications.

Mounting Bolts

Bolt kits must be ordered separately. Use Bolt Kit BKDG10-636-255636. Maximum recommended bolt torque is 210 lb. ft. (286 N.m).

Application Data

Fluid Cleanliness

Proper fluid condition is essential for long and satisfactory life of hydraulic components and systems. Hydraulic fluid must have the correct balance of cleanliness, materials, and additives for protection against wear of components, elevated viscosity, and inclusion of air.

Essential information on the correct methods for treating hydraulic fluid is included in Vickers publication 561 "Vickers Guide to Systemic Contamination Control" available from your local Vickers distributor or by

contacting Vickers, Incorporated. Recommendations on filtration and the selection of products to control fluid condition are included in 561.

Recommended cleanliness levels, using petroleum oil under common conditions, are based on the highest fluid pressure levels in the system and are coded in the chart below. Fluids other than petroleum, severe service cycles, or temperature extremes are cause for adjustment of these cleanliness codes. See Vickers publication 561 for exact details.

Vickers products, as any components, will operate with apparent satisfaction in fluids with higher cleanliness codes than those described. Other manufacturers will often recommend levels above those specified. Experience has shown, however, that life of any hydraulic component is shortened in fluids with higher cleanliness codes than those listed below. These codes have been proven to provide a long, trouble-free service life for the products shown, regardless of the manufacturer.

Product	System Pressure Level bar (psi)		
	<70 (<1000)	70-210 (1000-3000)	210+ (3000+)
Vane Pumps – Fixed	20/18/15	19/17/14	18/16/13
Vane Pumps – Variable	18/16/14	17/15/13	
Piston Pumps – Fixed	19/17/15	18/16/14	17/15/13
Piston Pumps – Variable	18/16/14	17/15/13	16/14/12
Directional Valves	20/18/15	20/18/15	19/17/14
Pressure/Flow Control Valves	19/17/14	19/17/14	19/17/14
CMX Valves	18/16/14	18/16/14	17/15/13
Servo Valves	16/14/11	16/14/11	15/13/10
Proportional Valves	17/15/12	17/15/12	15/13/11
Cylinders	20/18/15	20/18/15	20/18/15
Vane Motors	20/18/15	19/17/14	18/16/13
Axial Piston Motors	19/17/14	18/16/13	17/15/12
Radial Piston Motors	20/18/14	19/17/13	18/16/13

Fluids and Seals

Add "F3" prefix to model code for fluoro-carbon seals, suitable for use with phosphate ester type fluids or their blends. Standard Buna-N seals are suitable for water glycol, water-in-oil emulsion fluids and petroleum oil.

Viscosity Range

75 to 600 Ssu (15 to 128 cSt)

Operating Temperature Range

-18° to 66°C (0° to 150°F)

Notes

Eaton Hydraulics

15151 Highway 5
Eden Prairie, MN 55344
Telephone: 612 937-7254
Fax: 612 937-7130
www.eatonhydraulics.com

46 New Lane, Havant
Hampshire PO9 2NB
England
Telephone: (44) 170-548-6451
Fax: (44) 170-548-7110

